

THE DISTRICT BOARD OF TRUSTEES OF  
PENSACOLA STATE COLLEGE, FLORIDA  
1000 COLLEGE BOULEVARD  
PENSACOLA, FL 32504-8998

**BID 2-2013/2014**

**INVITATION TO BID (ITB)**  
**NEW POOL PIPING/EQUIPMENT AND LINER**

The District Board of Trustees of Pensacola State College hereby extends an Invitation to Bid (ITB) for NEW POOL PIPING/EQUIPMENT AND LINER for Pensacola State College, as specified in this bid request.

All terms and conditions included hereafter are part of this bid request. Any bid failing to comply with all of these terms and conditions may not be accepted.

Directions for submitting bids include the following:

1. All bids must be mailed or delivered to the attention of the Director of Purchasing and Auxiliary Services, and be received in the Purchasing and Auxiliary Services Office, Pensacola State College, Building 7, Room 737, 1000 College Boulevard, Pensacola, Florida 32504-8998, or delivered to the bid opening site, not later than **November 19<sup>th</sup> 2:00 p.m. local time** and shall be clearly marked **SEALED ITB 2-2013/2014 – NEW POOL PIPING/EQUIPMENT AND LINER** for Pensacola State College. Due to the requirement of sealed bidding, facsimile bids will not be acceptable as valid bid responses. All bids shall be submitted on the proposal form, herein included, and shall be properly signed by an authorized representative of the firm or entity submitting the bid in order to be considered. Attach all amplifying instructions and documents to this bid form. Questions must be submitted no later than 2:00 P.M., local time, November 7<sup>th</sup>, 2013 to [cboatwright@pensacolastate.edu](mailto:cboatwright@pensacolastate.edu).

An evaluation committee meeting is scheduled to be held at 2:30 P.M., local time, November 19<sup>th</sup>, 2013, in the Barfield Administration Building No. 7, Room 737, 1000 College Blvd, Pensacola, FL 32504.

Bid tabulations and award recommendations will be posted in the Purchasing Department, Pensacola State College. Posting normally occurs within 10 days of bid opening date at [http://www.pensacolastate.edu/purchasing/current\\_solicitations.asp](http://www.pensacolastate.edu/purchasing/current_solicitations.asp)

2. Any person(s) requiring reasonable accommodations, in accordance with the provisions of the American With Disabilities Act for attendance at the scheduled bid opening, shall contact the Office of the Director of Purchasing and Auxiliary Services, at least seventy-two (72) hours in advance of the scheduled bid opening deadline.
3. Price, quality, specifications and time of guaranteed delivery will be the determining factors in the award of the bid. Award will be made to the supplier offering the best total value to the College.
4. Any award on the basis of this bid will be contingent upon approval by The District Board of Trustees of Pensacola State College and the terms of the contract to be negotiated with the successful bidder. The award is based contingent upon available budget.
5. Proposals of \$200,000 including the cost of alternates or greater must be accompanied by a **5% proposal guarantee bond as described in the Instructions to Bidders**. Each proposal and proposal guarantee shall remain firm and binding for at least sixty (60) days to allow time for evaluation of bids by the Owner. The successful bidder will also be required to furnish

a 100% Performance and Payment Bond by a surety authorized to do business in the State of Florida that complies with Section 255.05 F.S. for any resulting awards of \$200,000 including cost of alternates or greater, as described in the contract documents.

6. To be eligible for award, bidder shall be licensed as required in Section 489, Florida Statutes, unless exempted as well as only use licensed subcontractors. The bidder is required to hold a Florida Commercial Pool Contractor License.

The College reserves the right to:

- accept or reject any bid/proposal or portion of a bid/proposal, or
- solicit best and final proposals, or
- issue request(s) for clarification/information, or
- to waive any informalities, or
- reject all proposals without further action, or
- re-advertise/re-solicit for bids/proposals, or
- reject all bids/proposals, as deemed in the College's best interest.

## **INSTRUCTIONS TO BIDDERS**

1. **EXPLANATIONS TO BIDDERS.** Any explanation desired by a bidder regarding the meaning or interpretation of the Invitation To Bid, drawings, specifications, Form of Agreement and Bond, etc. must be requested in writing from the College's Director of Purchasing and Auxiliary Services and with sufficient time allowed for a reply to reach all bidders before the submission of their proposals. Any interpretation made will be in the form of an addendum which will be furnished (mailed or emailed with read receipt) to all prospective bidders. Its receipt by the bidder must be acknowledged by one of the means set forth in the addendum prior to the time set for opening of proposals. Oral explanations and instructions given before the award of the contract will not be binding on the College.

2. **CONDITIONS AFFECTING THE WORK.** Bidders should visit the site and take such other steps as may be reasonably necessary to ascertain the nature and location of the work, and the general and local conditions which can affect the work or the cost thereof. Bidders and subcontractors/suppliers (at all tiers) should also carefully examine the drawings, specifications and related documents so that they are accurately informed regarding any and all conditions and requirements contained therein that may in any manner affect the work to be performed. Neither the Architect, nor the College will assume any responsibility for bidding errors and omissions caused by failure of the bidder or any of his subcontractors/suppliers (at all tiers) to visit the site or to inspect and familiarize themselves with the complete set of contract documents.

3. **ADDENDA.** Any addenda issued prior to the opening of bids for the purpose of changing the intent of the specifications and drawings, or clarifying the meaning of the same, shall be binding in the same way as if written in the specifications and drawings. Since all addenda are available to bidders at the Purchasing Office at the College and it is each bidder's responsibility to check with the issuing office and immediately secure all addenda before submitting bids. The College's Purchasing Office emails addenda to all prospective bidders, but no guarantee can be made that addenda will be received by anyone. The College posts all addenda on the Purchasing website referenced above.

4. **PREPARATION OF PROPOSALS.** (a) Proposals shall be submitted in duplicate on the forms furnished, or copies thereof, and must be manually signed. If erasures or other changes appear on the forms, each erasure or change must be initialed by the person signing the bid. Proposals must be typed or written in ink. (b) The proposal form may provide for submission of a price or prices for one or more items, which may be lump sum bids, alternate prices, scheduled items resulting in a bid on a unit of construction or a combination thereof, etc. Where the proposal form explicitly requires that the bidder bid on all items, failure to do so will disqualify the proposal. When submission of a price on all items is not required, bidders should insert the words "no bid" in the space provided for any item on which no price is submitted. All bid prices shall be stated in both words and numerals. (c) Unless called for, alternate bids or exclusions will not be considered and the bidder will be considered non-responsive.

5. **PROPOSAL GUARANTEE.** Where a proposal guarantee is required by the Invitation To Bid, failure to furnish a proposal guarantee in the proper form and amount, by the time set for opening of proposals, shall be cause for the rejection of the proposal. The proposal guarantee shall be in the form of a firm commitment, such as a certified or cashier's check on any national or state bank, or a bid bond issued by a Surety licensed to conduct business in the State of Florida, in a sum not less than five percent (5%) of the base bid, and made payable to Pensacola State College. Proposal guarantees, other than bonds, will be returned (a) to the unsuccessful bidders as soon as practicable after the opening of proposals, and (b) to the successful bidder upon execution of such further contractual documents and bonds as may be required by the proposal as accepted.

6. **SUBMISSION OF PROPOSALS.** Proposals must be sealed, marked and addressed as directed in the Invitation To Bid. Failure to do so may result in a premature opening of, or a failure to open, such proposal.

7. LIST OF SUBCONTRACTORS. The Bidder shall submit with his Proposal a list of subcontractors for trades designated as provided on form titled "Designated Subcontractors Form" in accordance with Article 5 of General Conditions.

9. LATE PROPOSALS AND MODIFICATIONS. (a) Proposals and modifications or withdrawals thereof received at the place designated in the Invitation To Bid after the exact time set for opening of proposals will not be considered unless, if submitted by mail, it is determined by the College that late receipt at the place of bid opening was caused solely by distribution delay within the College after receipt at the College's mail distribution center, provided that timely receipt is established upon examination of the time stamps of such installation.(b) The College reserves the right as deemed in its best interest to accept a late bid, if the College is provided within 48 hours of public opening, a letter from a commercial next day/air courier stating that the late delivery was due solely to their failure and that they had possession of the bid in time to meet the bid opening. (c) Hand-carried proposals must be received and time-stamped in at the place designated in the Invitation To Bid not later than the exact time set for opening of proposals. Late hand-carried bids will not be accepted. (d) A late bid modification which make the price and other terms of the otherwise successful bid more favorable to the Owner, and which under ordinary circumstances would have arrived on time, as herein described, will be considered at any time it is received.

10. WITHDRAWAL OF PROPOSAL. A bidder may withdraw his Proposal without prejudice to himself, not later than the date and time set for opening of bids, by communicating his purpose in writing to the College. His proposal will be returned to him unopened.

11. SIGNATURE ON PROPOSAL. The bidder must sign his Proposal correctly. If the Proposal is made by an individual, his name, post office address (including ZIP), and telephone number shall be shown. If made by a firm or partnership, the name and post office address of each member of the firm or partnership shall be shown. If made by a corporation, the person signing the Proposal shall show the name of the state under the laws of which the corporation was chartered, also the name and business address of its president, secretary and treasurer. Anyone signing the Proposal as agent shall file with the Proposal legal evidence of his authority to do so.

12. BIDDER. "Bidder" means an individual, firm or corporation submitting a Proposal to the Owner for the work contemplated.

13. PUBLIC OPENING OF PROPOSALS. Proposals will be publicly opened at the time set for opening in the Invitation To Bid. At the appointed time and place, the Owner's representative will announce the close of bidding and commence with the public bid opening. Bidders are invited to attend the proceedings.

14. Pursuant to HB 7223/FS 119.071 the College may choose to not read aloud the individual bid prices at the Public Opening and only open individual bids/proposals and announce who a bid/proposal was received from. The actual bid prices submitted will not be a public record until the date of posting (defined herein) or 30 days after bid opening (whichever is earlier) as defined in FS 119.071. The actual bid prices will be posted for a 72-hour period after the posting time and date on the College's Purchasing Department's website for the information of bidders and others interested, and those who may be present during the bid opening either in person or by representative.

15. QUALIFICATIONS OF BIDDER. In order to be qualified, bidders shall, prior to the time of submitting a bid, be qualified under appropriate local and state regulations or statutes to perform the work required and submit a copy of your current license with your bid. In particular (but not exclusively) bidders are referred to Chapter 489, Florida Statutes for specific qualification requirements. Before a bid is considered for award, the bidder may be requested by the College to submit a

statement regarding his previous experience in performing comparable work, his business and technical organization, financial resources, and plan available to be used in performing the work.

16. AWARD OF CONTRACT. (a) Award of contract will be made to that responsible bidder whose proposal, conforming to the Invitation To Bid and all addenda plus specifications without exclusions, is most advantageous to the College, price and other factors considered. (b) Bids will be evaluated and award made on the basis of the Lump Sum Base Bid, or Lump Sum Base Bid plus or minus Alternate Additive or Deductive Bid Items in the order of priority within the funds available for award. BIDDERS MUST BID ALL ALTERNATE BID ITEMS IN ORDER TO BE ELIGIBLE FOR AWARD.

17. CONTRACT AND BONDS. The bidder whose proposal is accepted will, within the time established in the proposal, enter into a written contract with the College and, if required, furnish acceptable performance and payment bonds and a certificate of insurance on specified forms in the amounts indicated in the Invitation To Bid or the specifications. If the successful bidder, upon acceptance of his proposal by the College within the period specified therein for acceptance (thirty days if no period is specified) fails to execute such further contractual documents, if any, and give such acceptable bond(s) and insurance certificate as may be required by the terms of the proposal as accepted within the time specified, fails to execute such further contractual documents, if any, and give such acceptable bond(s) and insurance certificate as may be required by the terms of the proposal as accepted within the time specified (ten days if no period is specified) after receipt of the forms by him, his contract may be terminated for default. In such event he shall be liable for any cost of procuring the work which exceeds the amount of his proposal, and the proposal guarantee shall be available toward offsetting such difference.

No contract shall be considered binding upon the College until it has been properly executed.

18. RECORDING PERFORMANCE AND PAYMENT BONDS. Chapter 88-397, Laws of Florida, modifies FS255.05 (1) (a) to require any person entering into a formal contract for public work ... to record in the public records of the county where the improvement is located, the payment and performance bond furnished for the improvement.

19. DISQUALIFICATION OF BIDDERS. No bidder shall submit more than one proposal, and reasonable grounds for believing that a bidder has an interest in more than one proposal for the same work will cause rejection of all proposals in which such bidder, or bidders, are believed to be interested. Any or all proposals will be rejected if there is reason to believe that collusion exists among the bidders and no participants in such collusion will be considered in future proposals for the same work.

20. FAMILIARITY WITH LAWS. The bidder is assumed to be familiar with all Federal, State and local laws, ordinances, rules and regulations that in any manner affect the work. Ignorance on the part of the bidder will in no way relieve him from responsibility.

21. FLORIDA PRODUCTS AND LABOR. The contractor's attention is called to Section 255.04, Florida Statutes, which require that on public building contracts, Florida products and labor shall be used wherever price and quality are equal.

22. SALES AND USE TAXES. Although the College is not subject to the Florida Sales and Use Tax, any contractor who purchases materials which will be used in the construction of a state-owned building will not be exempted from the sales tax on these materials.

23. EQUALITY AND SUBSTITUTIONS. Reference is made to paragraph 7.10.2 in the General Conditions. If the bidder proposes to furnish a 'different' product from that specified, he shall submit in writing two copies of detailed specifications and catalog cuts (with information copy to the College's Purchasing Office) clearly identified, and clearly stating the differences from the product specified, ten (10) days prior to the bid opening to the Architect (address below) for evaluation and

approval to bid. Submittal of substitutions with a bid that has not been authorized by an ITB addenda issued will constitute the bid being considered non-responsive. The College's Director of Purchasing and Auxiliary Services will issue an addendum at least seven (7) days prior to the bid opening date adding acceptable equivalent items to the bid items involved. The Owner and the Architect shall not be responsible for locating or securing any information which is not identified properly on the information supplied for evaluation of the proposed equivalent product.

24. Proposals/bids submitted shall not include any closed proprietary architecture equipment systems. Responsive proposals/bids shall assure an open architecture (i.e. generic in nature) where parts available, maintenance and repair of said equipment/systems are not restricted to only the original equipment manufacturer. Bidders must disclose with their proposal/bid any closed architecture equipment/system for College evaluation/determination of responsiveness.

25. IDENTICAL OR TIE BIDS: The decision for the award of tie bids shall be made after a careful review of the circumstances surrounding the tie, with preference being given to State of Florida bidders, secondly to drug free State of Florida bidders, or finally by flip of coin, when all other factors are equal.

26. DISCRIMINATION: In accordance with HB 2127, Section 6(3)(a), all Invitations To Bid, as defined by 287.012(11)FS, Requests For Proposals, as defined by 287.012(15), and any written contract document of the State shall contain a statement informing entities of the discrimination provisions of paragraph (2)(a).

An entity or affiliate who has been placed on the discriminatory vendor list may not submit a bid on a contract to provide goods or services to a public entity, may not submit a bid on a contract with a public entity for the construction or repair of a public building or public work, may not submit bids on leases of real property to a public entity, may not award or perform work as a contractor, supplier, subcontractor, or consultant under contract with any public entity, and may not transact business with any public entity.

28. INSURANCE: Pursuant to Senate Bill 50A and FS Chapter 440: During the Contract term, the Contractor at its sole expense shall provide commercial insurance of such a type and with such terms and limits as may be reasonably associated with the Contract, which, at a minimum, shall be: as defined in the General Conditions.

29. CONFLICT OF INTEREST: Pursuant to Florida Statutes effective 1/1/2004 employers who have employees who are engaged in work in Florida must use Florida rates, rules and classifications for those employees. In the construction industry, only corporate officers of a corporation or any group affiliated corporations may elect to be exempt from workers' compensation coverage requirements. Such exemptions are limited to a maximum of three per corporation and each exemption holder must own at least 10% of the corporation. Independent contractors, sole proprietors and partners in the construction industry cannot elect to be exempt and must maintain worker' compensation insurance.

## BID SPECIFICATIONS

This bid includes the replacement of the pool liner and piping/equipment replacement. The first section of the bid includes the specifications for the pool liner replacement. The drawings (Attachment A) contain the specifications for pool piping and equipment.

Replacement of Pool Liner

Size: 75.0' x 45.0' (verify dimensions) – 160,000 gallons (approx.)

Furnish and install a Natatec PVC Membrane System, or equivalent, for the pool consisting of the system components as listed below.

Removal of existing lining system and place into a contractor provided dumpster.

Surface preparation consisting of broom-cleaning the existing pool interior.

Remove any spalling and patch where required.

Patch any and all cracks.

Apply Natatstat Microbiocide, or equivalent, to existing pool substrate to deter the growth of bacteria and microbes beneath the membrane.

Adhere 11 oz. Geotextile Fleece Separator to the existing pool surfaces.

Anchor polymer expansion joint bridging to one side of existing expansion joint.

Anchor PVC coated steel flats and/or angles to pool substrate as required to facilitate attachment of PVC membrane.

Install Natatec Type ND (smooth), or equivalent, 60 mil polyester reinforced PVC membrane to pool floor.

Install Natatec Type ND (smooth), or equivalent, 60 mil polyester reinforced PVC membrane to pool walls.

Install Natatec Type ND (textured), or equivalent, 60 mil polyester reinforced PVC membrane to horizontal surfaces requiring slip-resistant texture.

Black PVC membrane material (lane markings, wall targets, and transition indicators will be installed to match submittal documents or existing pool markings).

Install corrosion resistant anchors and fasteners.

Install semi-ridged PVC compression/termination flange with interlocking PVC closer cap.

Surface preparation consisting of broom-cleaning the existing pool interior.

Polymer and/or PVC pressure flanges shall be furnished and installed for all inlets, outlets, main drains, underwater lights, anchor sockets and other necessary membrane penetrations.

Fuse welded, overlapping seams using hot-air welding techniques. Exposed edges of seams to be sealed with PVC solution.

Provide pool lining 10 year warranty. Detailed warranty information must be submitted with bid.

**Drawings (Attachment A) labeled New Pool Piping/Equipment detail the additional bid specifications.**

## GENERAL CONDITIONS OF THE CONTRACT FOR CONSTRUCTION

These General Conditions are made part of this specifications by incorporation or reference, are applicable to all Divisions and Sections of the Specifications; and it is the Contractor's responsibility to so inform all parties who should be influenced thereby.

### ARTICLE 1.0 CONTRACT DOCUMENTS

#### 1.1 DEFINITIONS

##### 1.1.1 THE CONTRACT DOCUMENTS

The Contract Documents consist of the following:

- (a) The executed Agreement Between Owner and Contractor
- (b) Conditions of the Contract (General, Supplementary, and Special Conditions) and Attachments thereto
- (c) Performance Bond
- (d) Labor and Material Payment Bond
- (e) Drawings
- (f) Specifications
- (g) Addenda issued prior to execution of the Contract
- (h) Modifications issued after execution of the Contract

##### 1.1.2 THE CONTRACT OR PURCHASE ORDER

The contract will be executed in accordance with these General Conditions, and also incorporates the instructions to bidders, bid specifications, and drawings. The Contract represents the entire and integrated agreement and supersedes all prior negotiations, representations, or agreements, either written or oral, including the bidding documents. The Contract may be amended or modified only by a Modification as defined in Subparagraph 1.1.5.

##### 1.1.3 THE PROJECT

The Project is the total construction to be built on the site as established by the bid specifications and accompanying drawings.

##### 1.1.4 THE WORK

The work is defined as all labor, materials and equipment to be incorporated into the project under the terms of this contract.

##### 1.1.5 MODIFICATION TO THE CONTRACT

A Modification may be made only after execution of the Contract requires an authorized Change Order Purchase Order.

#### 1.2 EXECUTION, CORRELATION, INTENT, AND INTERPRATIONS

1.2.1 The Contract shall be executed by the College for distribution to the Contractor and Architect.

1.2.2 By executing the Contract, the Contractor agrees that he has carefully examined the Contract Documents together with the site of the proposed Work as well as its surrounding territory, that he is fully informed regarding the conditions affecting the work to be done and the labor and materials to be furnished for the completion of the Work.

1.2.3 The Contract Documents are complementary, and what is required by any one shall be as binding as if required by all. The intention is to include all labor, materials, supplies, equipment and tools necessary for the proper execution and completion of the Work. It is not intended that Work not covered under any heading, section, or division of the Specifications shall be supplied unless it is required



elsewhere in the Contract Documents or is reasonably inferable therefrom as being necessary to produce the intended results. Words which have well-known technical or trade meanings are used herein in accordance with such recognized meanings.

1.2.4 Drawings and Specifications are intended to be complementary and to provide for a complete work.

The Contractor acknowledges that the Contract consideration includes sufficient money allowances to make his Work complete and operational and in compliance with good practice and he agrees that inadvertent minor discrepancies or the failure to show details or to repeat on any part of the Contract Documents, the figures or notes given on another, shall not be the cause of additional charges or claims.

Where contradictions occur within the specifications or the drawings, with regard to the quantity, quality or method of installation of a particular item, the Contractor shall include in his bid the cost for furnishing the more expensive item or installation of the greater quantity without exception.

The following shall be given preference - in the order hereinafter set forth to determine what work the Contractor is to perform. 1) Addenda (later dates to take precedence over earlier dates), 2) Modifications, 3) Agreement, 4) Specifications, 5) Schedules, 6) Large Scale Detail Drawings, 7) Small Scale Plan and Section Drawings. Dimensioned Drawings shall govern over scaled drawings. Existing conditions, including dimensions, shall be verified by the Contractor before laying out the Work.

1.2.5 Much of these specifications are written in an abbreviated form and may include sentence fragments. Omissions of words or phrases as "the Contractor shall", "in conformity with", "shall be", "as noted on the Drawings", "according to the plans", "a", "an", "the", and "all" are intentional. Omitted words and phrases shall be supplied by inference in the same manner as they are when a "note" occurs on the Drawings.

1.2.6 Where such words as "as shown", "as indicated", "as noted", or words of similar import are used, they shall refer to the Drawings. Where references are made to "sections" and "divisions" it shall mean sections and divisions of the Specifications unless otherwise stated. Where such words as "as selected", "as approved", "acceptable" or "approved" occur, they shall have reference to the selection and approval of the Architect unless otherwise stated. Where sentence complete, the material or item specified, excepting those materials indicated to be Owner furnished and Contractor installed.

1.2.7 The organization of the Specifications into divisions, sections and articles, and the arrangement of Drawings shall not control the Contractor in dividing the Work among the Subcontractors or in establishing the extent of Work to be performed by any trade.

1.2.8 Written interpretations necessary for the proper execution of progress of the Work, in the form of drawings or otherwise, will be issued with reasonable promptness by the Architect for such interpretations. Such interpretations shall be consistent with and reasonably inferable from the Contract Documents and shall be promptly rendered by the Architect.

### 1.3 COPIES FURNISHED AND OWNERSHIP

1.3.1 The Contractor will be furnished, free of charge, copies of Drawings and Specifications as provided in the Supplementary Conditions.

1.3.2 All Drawings, Specifications and copies thereof furnished by the Owner are and shall remain his property. They are not to be used on any other project, and, with the exception of one contract set for each party to the Contract, are to be returned to the Owner on request at the completion of the Work.

**ARTICLE 2.0  
ARCHITECT**

**ARTICLE 2.0 IS NOT APPLICABLE FOR THIS PROJECT. ANY REFERENCE TO "ARCHITECT" THROUGHOUT THIS INVITATION SHALL BE CONSIDERED THE RESPONSIBILITY OF THE OWNER.**

2.1 DEFINITIONS

2.1.1 The Architect-Engineer shall be the firm listed in "Instruction To Bidders", paragraph 23 and shall act as defined below either directly or through duly authorized personnel.

2.1.2 Contractor shall schedule regular project meetings at the project site with the Owner and the A/E of record where the Contractor shall take meeting minutes and publish meeting minutes to all meeting attendees within 48 hours of the meeting. The Architect and Owner will review the meeting minutes for accuracy and respond back to Contractor with any discrepancies that are discovered. The Contractor will amend the meeting minutes accordingly for distribution and acceptance at the next scheduled project meeting.

2.2 ADMINISTRATION OF THE CONTRACT

2.2.1 The Architect will provide general Administration of the Construction Contract, including performance of the functions hereinafter described.

2.2.2 The Architect will be the Owner's representative during construction and until final payment. The Architect will have authority to act on behalf of the Owner as Owner's representative to the extent provided in the Contract Documents, unless otherwise modified by written instrument which will be shown to the Contractor. The Architect will advise and consult with the Owner, and all of the Owner's instructions to the Contractor shall be issued through the Architect.

2.2.3 The Architect and the Owner shall at all times have access to the Work wherever it is in preparation and progress.

2.2.4 The Architect will provide on-site surveillance to check the quality and progress of the Work and to determine in general if the Work is being installed in accordance with the Contract Documents. The Architect shall periodically visit the job site to check the quality of the Work being installed. On the basis of his on-site observations, the Architect shall keep the Owner informed on the Progress of the Work and will endeavor to protect him against defects and deficiencies in the Work of the Contractor. The Architect will not be responsible for construction means, methods, techniques, sequences or procedures of construction, or safety precautions and programs in connection with the Work, and he will not be responsible for the Contractor's failure to carry out the Work in accordance with the Contract Documents.

2.2.5 Based on the above on-site observations and the Contractor's Application for Payment, the Architect will determine the amounts owing to the Contractor and will issue Certificates for Payment in amounts consistent with the approved Schedule of Values (Reference 9.2.1).

The Architect shall, to the best of his ability, determine that the work installed is in conformance with the construction documents.

The Architect must certify on each Application for Payment that such payment is due before any payment is made.

Such certification by the Architect does not in any way relieve the Contractor of his final responsibility for conformity with plans and specifications.

2.2.6 The Architect will be the interpreter of the requirements of the Contract Documents and the judge of the performance thereunder by the Contractor. The Architect will, within a reasonable time, render such interpretations as he may deem necessary for the proper execution and progress of the Work.

2.2.7 Claims, disputes and other matters in question relating to the execution or progress of the Work or the interpretation of the Contract Documents shall be referred initially to the Architect and the Owner for a decision which will be rendered in writing by the Architect within a reasonable time.

2.2.8 All interpretations and decisions of the Architect shall be consistent with the intent of the Contract Documents.

2.2.9 The Architect's decision in matters relating to artistic effect will be final if consistent with the intent of the Contract Documents.

2.2.10 Any Claim, dispute or other matter that has been referred to the Architect, except those relating to artistic effect as provided in Subparagraph 2.2.9 and except any which have been waived by the making or acceptance of final payment as provided in Paragraph 9.7, shall be subject to arbitration upon the written demand of any party, in accordance with Paragraph 7.9. However, no demand for arbitration of any such claim, dispute or other matter may be made until the earlier of:

- (a) the date on which a written decision has been rendered, or,
- (b) the tenth day after the parties have presented their evidence to the Architect or have been given a reasonable opportunity to do so, if no written decision has been rendered by that date.

2.2.11 If a decision is made in writing and states that it is final but subject to appeal, no demand for arbitration of a claim, dispute or other matter covered by such decision may be made later than thirty days after the date on which the party making the demand received the decision. The failure to demand arbitration within said thirty days period will result in the Architect's decision becoming final and binding upon the Contractor. If a decision is rendered after arbitration proceedings have been initiated, such decision may be entered as evidence but will not supersede any arbitration proceedings unless the decision is acceptable to the parties concerned.

2.2.12 The Architect will have authority to reject Work which does not conform to the Contract Documents or has been damaged prior to approval of final payment. Whenever, in his reasonable opinion, he considers it necessary or advisable to insure the proper implementation of the intent of the Contract Documents, he will have authority to require special inspection or testing of the Work in accordance with Subparagraph 7.8.2 whether or not such Work be then fabricated, installed or completed. However, neither his authority to act under this Subparagraph 2.2.12, nor any decision made by him in good faith either to exercise or not to exercise such authority, shall give rise to any duty or responsibility of the Architect to the Contractor, any Subcontractor, any of their agents or employees, or any other person performing any of the work.

2.2.13 The Architect will review Shop Drawings and Samples as provided in Paragraph 4.13.

2.2.14 The Architect will prepare change orders in accordance with Article 12.

2.2.15 The Architect will conduct inspections to determine the dates of Substantial Completion and Final Completion, will receive and review written guarantees and related documents

required by the Contract and assembled by the Contractor and will recommend a Final Certificate of Payment to the Owner.

2.2.16 The duties, responsibilities and limitation of authority of the Architect as the Owner's representative during construction as set forth in Articles 1 through 15 inclusive of these General Conditions will not be modified or extended without written consent of the Owner, Contractor and Architect.

2.2.17 The Architect will not be responsible for the acts or omissions of the Contractor, any Subcontractors or any of their agents or employees or any other persons at the site or otherwise performing of the Work.

2.2.18 In case of the termination of the employment of the Architect, the Owner shall appoint an Architect whose status under the Contract Documents shall be that of the former Architect.

### **ARTICLE 3.0 OWNER**

#### 3.1 DEFINITION

3.1.1 The Owner is the District Board of Trustees Pensacola State College, identified as such in the Agreement and is referred to throughout the Contract Documents. The term Owner means the Owner or his authorized representative.

#### 3.2 INFORMATION AND SERVICES REQUIRED OF THE OWNER

3.2.1 The Owner shall furnish all surveys describing the physical characteristics, subsurface conditions, legal limits and utility locations for the site of the Project including investigative reports, all of which have been relied upon by the Architect in preparing Drawings and Specifications, if available.

3.2.2 Should conditions encountered below the surface of the ground vary to an unreasonable extent from the conditions indicated by the Drawings and Specifications, the Architect shall be notified by the Contractor and instructions shall have been received from the Architect prior to the Contractor's proceeding with the Work involved. Core boring data, including ground-water elevations or conditions, if shown on the Drawings or attached to these Specifications, are presented only as information that is available indicating certain conditions found and limited to the exact locations shown. Neither the Owner nor the Architect shall be responsible for variations found to exist between the data referred to and actual field conditions that develop through the period of construction. The Contractor shall be responsible for making his own determination of water table variations prior to bidding and shall not assume that any water levels shown by the aforesaid core boring data will necessarily be maintained at the level indicated.

3.2.3 The Owner shall secure and pay for easements for permanent structures or permanent changes in existing Facilities.

3.2.4 Information or services under the Owner's control shall be furnished by the Owner with reasonable promptness to avoid delay in the orderly progress of the Work.

3.2.5 The Owner shall issue all instructions to the Contractor.

3.2.6 The foregoing are in addition to other duties and responsibilities of the Owner enumerated herein and especially those in respect to Payment and Insurance.

#### 3.3 OWNERS RIGHT TO STOP WORK

3.3.1 If the Contractor fails to correct defective Work or persistently fails to supply materials or equipment in accordance with the Contract Documents, the Owner may order the Contractor to stop the

Work, or any portion thereof, until the cause for such order has been eliminated. The Contractor will not be entitled to a time extension of the contract completion time in the event the Owner exercises his rights under this paragraph.

#### 3.4 OWNER'S RIGHT TO CARRY OUT THE WORK

3.4.1 If the Contractor defaults or neglects to carry out the Work in accordance with the Contract Documents or fails to perform any provision of the Contract, the Owner may, after seven (7) days written notice to the Contractor and without prejudice to any other remedy he may have, make good such deficiencies. In such case an appropriate Change Order shall be issued deducting from the payments then or thereafter due the Contractor the cost of correcting such deficiencies, including the cost of the Architect's additional services made necessary by such default, neglect or failure. The Architect must approve both such action and the amount charged to The Contractor. If the payments then or thereafter due the Contractor are not sufficient to cover such amount, the Contractor shall pay the difference to the Owner.

### **ARTICLE 4.0 CONTRACTOR**

#### 4.1 DEFINITION

4.1.1 The Contractor is the person or organization identified as such in the Agreement and is referred to throughout the Contract Documents as if singular in number and masculine in gender. The term Contractor means the Contractor or his authorized representative who is licensed to do business by all applicable laws.

#### 4.2 REVIEW OF CONTRACT DOCUMENTS

4.2.1 The Contractor shall carefully study and compare the Contract Documents and shall at once report to the Architect any error, inconsistency or omission he may discover. The Contractor shall not be liable to the Owner or the Architect for any damage resulting from any such errors, inconsistencies or omissions in the Contract Documents provided they are reported as outlined above. The Contractor shall do no Work without Contract Documents.

#### 4.3 SUPERVISION AND CONSTRUCTION PROCEDURES

4.3.1 The Contractor shall supervise and direct his Work, using his best skill and attention. He shall be solely responsible for all construction means, methods, techniques, sequences and procedures and for coordinating all portions of the Work under the Contract.

#### 4.4 LABOR AND MATERIALS

4.4.1 Unless otherwise specifically noted, the Contractor shall provide and pay for all labor, materials, equipment, tools, construction equipment and machinery, transportation, and other facilities and services necessary for the proper execution and completion of the Work.

#### 4.5 WARRANTY

4.5.1 The Contractor warrants to the Owner and the Architect that all materials and equipment furnished under this contract will be new unless otherwise specified, and that all Work will be of good quality, free from faults and defects and in conformity with the Contract Documents. All work not so conforming to these standards at the time of acceptance or at the time of inspections, tests or approvals, shall be considered defective. If required by the Architect, the Contractor shall furnish satisfactory evidence as to the kind and quality of material and equipment.

#### 4.6 TAXES

4.6.1 The Contractor shall pay all sales, consumer, use and other similar taxes required by law.

#### 4.7 PERMITS, FEES AND NOTICES

4.7.1 The Contractor shall secure and pay for all permits, governmental fees and licenses necessary for the proper execution and completion of the Work, which are applicable at the time the bids are received. Contractor shall submit a current copy of your Professional License(s) with your bid. Educational facilities are exempt from assessments of fees for building permits, ordinances, and impact fees or service availability fees as set forth in Florida Statute 235.26(1).

4.7.2 The Contractor shall give all notices and comply with all laws, ordinances, rules, regulations and order of any public authority bearing on the performance of the Work. If the Contractor observes that any of the Contract Documents are at variance therewith in any respect, he shall promptly notify the Architect in writing, and any necessary changes shall be adjusted by appropriate Modification. If the Contractor performs any Work knowing it to be contrary to such laws, ordinances, rules and regulations, and without such notice to the Architect he shall assume full responsibility therefore and shall bear all costs attributed thereto.

4.7.3 Contractor shall save harmless the Owner and Architect against any claim or liability arising from or based upon the violation of law, ordinance or regulation, whether by himself, his employees, or any subcontractor.

4.7.4 Contractor shall pay all connection charges for utilities and inspection charges of public and private bodies.

4.7.5 Pensacola State College issues its own Building Permits and performs its own Building Inspections in accordance with the Florida Building Code. Currently there is no charge to the Contractor for the Building Permit, Project Plan Review or the Building Inspections. The quantity and types of project inspections are job specific in the general areas of Demolition, Building, Plumbing, Heating and Air Conditioning, Fire Protection, and Civil. It is the Contractor's responsibility to request all inspections. A re-inspection fee of \$50.00 per re-inspection will be charged to the contractor if a contractor requests/schedules an inspection on a project and it is not ready for inspection and a return re-inspection visit is required.

#### 4.8 CASH ALLOWANCES

4.8.1 No cash allowances are specified in the project. Submitted bids with allowances not specified will be cause for considering your bid non-responsive.

#### 4.9 SUPERINTENDENT

4.9.1 The Contractor shall employ a competent superintendent and necessary assistants who shall be in attendance at the Project site during the progress of the Work. The Superintendent shall be satisfactory to the Architect and shall not be changed except with the consent of the Owner, unless the Superintendent proves to be unsatisfactory to the Contractor and ceases to be in his employ. The Superintendent shall represent the Contractor and all communications given to the Superintendent shall be as binding as if given to the Contractor. Important communications will be confirmed in writing. Other communications will be so confirmed on written request in each case.

#### 4.10 RESPONSIBILITY FOR THOSE PERFORMING THE WORK

4.10.1 The Contractor shall be responsible to the Owner for the acts and omissions of all his employees and all Subcontractors, their agents and employees, and all Sub-subcontractors, their agents and employees, and all other persons performing any of the Work under a contract with the Contractor.

4.10.2 The Contractor shall at all times enforce strict discipline and good order among his employees and shall not employ on the Work any unfit person or anyone not skilled in the task assigned to him. The Owner may require the removal of disorderly employees.

#### 4.11 PROGRESS SCHEDULE

4.11.1 The Contractor, immediately after being awarded the Contract, shall prepare and submit for the Architect's approval an estimated progress schedule for the Work. The progress schedule shall be related to the entire Project to the extent required by the Contract Documents. This schedule shall indicate the dates for the starting and completion of the various stages of construction and shall be revised as required by the conditions of the Work, subject to the Architect's approval.

4.11.2 Within five (5) working days after the commencement of any condition which is causing or may cause delay in completion, the Contractor must notify the Architect and the Owner in writing of the effect, if any, of such conditions on the time progress schedule, and must state why and in what respects, if any, the condition is causing or may cause such delay.

#### 4.12 DRAWINGS AND SPECIFICATIONS AT THE SITE

4.12.1 One set of Drawings, marked to record all changes made during construction, shall be delivered to the Architect for the Owner upon completion of the Work.

#### 4.13 SHOP DRAWINGS AND SAMPLES

4.13.1 Shop Drawings are drawings, diagrams, illustrations, schedules, performance charts, brochures and other data which are prepared by the Contractor or any Subcontractor, manufacturer, supplier or distributor, and which illustrate some portion of the Work.

4.13.2 Samples are physical examples furnished by the Contractor to illustrate materials, equipment or workmanship, and to establish standards by which the Work will be judged.

4.13.3 Within ten (10) working days of the date of contract award, the Contractor shall furnish to the Architect a schedule of shop drawings and samples to be submitted for review. This schedule shall indicate an estimated total number of drawings and samples and a timed sequence for their submission and approval. When approved by the Architect this shop drawing schedule shall be incorporated into the overall schedule.

4.13.4 The Contractor shall review, stamp with his approval and submit in accordance with the above schedules, all Shop Drawings and Samples required by the Contract Documents. Shop Drawings and Samples shall be identified in a manner acceptable to the Architect. At the time of submission the Contractor shall inform the Architect in writing of any deviation in the Shop Drawings or Samples from the requirement of the Contract Documents.

4.13.5 The Contractor shall submit to the College five (5) copies, or at the College's option, one (1) reproducible copy and one (1) print, of all Shop Drawings required for the Work of the various trades.

4.13.6 By approving and submitting Shop Drawings and Samples, the Contractor thereby agrees that he has determined and verified all field measurements, field construction criteria, materials, catalog numbers and similar data, or will do so, and that he has checked and coordinated each Shop Drawing and Sample with the requirements of the Work and of the Contract Documents.

In checking his Shop Drawings prior to submittal, the Contractor is requested to note his corrections or comments on the Drawings in orange pencil.

4.13.7 The Architect will review and approve Shop Drawings and Samples with reasonable promptness so as to cause no delay, but only for conformity with the design concept of the Project and with the information given in the Contract Documents. The Architect's approval of a separate item shall not indicate approval of an assembly in which the item functions.

4.13.8 Drawings returned to the Contractor will be stamped either "Approved", "Approved as Noted", "Returned for Corrections", or "Not Approved". Those drawings stamped "Approved as Noted" need not be returned for further approval if the notations are acceptable to the Contractor and Subcontractors. Drawings stamped "Returned for Corrections" or "Not Approved" shall require new submission.

4.13.9 The Contractor shall make any corrections required by the Architect and shall resubmit the corrected copies of Shop Drawings or submit new samples until approved. The Contractor shall direct attention in writing to revisions other than the corrections requested by the Architect on previous submissions.

4.13.10 Appropriate catalogue cuts may be submitted for approval by the Contractor where applicable.

4.13.11 The Architect's approval of Shop Drawings or Samples shall not relieve the Contractor of responsibility for any deviation from the requirements of the Contract Documents unless the Contractor has informed the Architect in writing of such deviation at the submission and the Architect has given written approval to the specific deviation, nor shall the Architect's approval relieve the Contractor from responsibility for errors or omissions in the Shop Drawings or Samples.

4.13.12 No portion of the Work requiring a Shop Drawing or sample submission shall be commenced until the submission has been approved by the Architect unless the Architect specifically in writing cancels this requirement.

#### 4.14 USE OF SITE

4.14.1 The Contractor shall confine operations at the site to areas permitted by law, ordinances, permits and the Contract Documents and shall not unreasonably encumber the site with any materials or equipment.

4.14.2 The Contractor shall be responsible for any encroachments on rights or property of the public or adjoining property owners and shall hold the Owner and Architect harmless because of any encroachments which may be a result of his lack of proper layout. In this regard he shall, without extra cost to the Owner, remove any Work or that portion of any Work that encroaches on the property of others, or that is built beyond legal building or setback limits, and he shall rebuild the affected Work or portion of Work at the proper location and in full compliance with the Contract Documents.

#### 4.15 CUTTING AND PATCHING OF WORK

4.15.1 The Contractor shall be responsible for any cutting, fitting and patching that may be required to complete his Work except as otherwise specifically provided in the Contract Documents. The Contractor shall not endanger any work of any other contractors by cutting, excavating or otherwise altering any work and shall not cut or alter the work of any other contractor except with the written consent of the Architect.

#### 4.16 COMMUNICATIONS

4.16.1 Contractor shall schedule regular project meetings at the project site with the Owner where the Contractor shall take meeting minutes and publish meeting minutes to all meeting attendees within 48 hours of the meeting. The Owner will review the meeting minutes for accuracy and respond back to Contractor with any discrepancies that are discovered. The Contractor will amend the meeting minutes accordingly for distribution and acceptance at the next scheduled project meeting.



4.17 INDEMNIFICATION

4.17.1 To the full extent permitted by law, the Contractor shall indemnify and hold harmless the Owner and the Architect and their agents and employees from and against all claims, damages, losses and expenses, including but not limited to attorneys' fees, arising out of or resulting from the performance of the Work defined in the ITB, addenda and all specifications without exception, provided that any such claim, damage, loss or expense (1) is attributable to bodily injury, sickness, disease or death, or to injury to or destruction of personal property including the loss of use resulting there from, and (2) is caused in whole or in part by an negligent act or omission of the Contractor, any Subcontractor, anyone directly or indirectly employed by any of them or anyone for whose acts any of them may be liable, regardless of whether or not it is caused in part by the negligence of a party indemnified hereunder. Such obligations shall not be construed to negate, abridge, or otherwise reduce any other right or obligation of indemnity which would otherwise exist as to any party or person described in this Paragraph 4.17.

4.17.2 In any and all claims against the Owners or the Architect or any of their agents or employees by any employee of the Contractor, any Subcontractor, anyone directly or indirectly employed by any of them or anyone for whose acts any of them may be liable, the indemnification obligation under this Paragraph 4.17 shall not be limited in any way by any limitation on the amount or type of damages, compensation or benefits payable by or for the Contractor or any Subcontractor under workers' or workmen's compensation acts, disability benefit acts or other employee benefit acts.

4.17.3 The obligations of the Contractor under this Paragraph 4.17 shall not extend to the liability of the Architect, his Agent or employees, arising out of (1) the preparation or approval of maps, drawings, opinions, reports, surveys, change orders, designs or specifications, or (2) the giving of or the failure to give directions or instructions by the Architect, his Agents or employees provided such giving or failure to give is the primary cause of the injury or damage.

4.18 CLEANING UP

4.18.1 The Contractor at all times shall keep the premises free from accumulation of waste materials or rubbish caused by his operations. At the completion of the Work he shall remove all his waste materials and rubbish from and about the Project as well as all his tools, construction equipment, machinery and surplus materials, and shall clean all glass surfaces and leave the Work "broom clean" or its equivalent, except as otherwise specified.

4.18.2 If the Contractor fails to clean up, the Owner may do so and the cost thereof shall be charged to the Contractor as provided in Paragraph 3.4.

4.18.3 If a dispute arises between the separate contractors as to their responsibility for cleaning up as required by paragraph 4.18.1, the Owner may clean up and charge the cost thereof to the several contractors as the Architect may determine to be just.

**ARTICLE 5.00  
SUBCONTRACTORS**

5.1 DEFINITIONS

5.1.1 A Subcontractor is a person or organization who has a direct contract with the Contractor to perform any of the Work at the site. The term Subcontractor is referred to throughout the Contract Documents as if singular in number and masculine in gender and means a Subcontractor or his authorized representative who is licensed to do business by the applicable law. It shall be the contractor's responsibility to provide the College the current license number of each subcontractor and to confirm their license is still valid.

5.1.2 A Sub-subcontractor is a person or organization who has a direct or indirect contract with a Subcontractor to perform any of the Work at the site. The term Sub-subcontractor is referred to throughout the Contract Documents as if singular in number and masculine in gender and means a Sub-subcontractor or an authorized representative thereof who is licensed to do business by the law of the place where the Project is located.

5.1.3 Nothing contained in the Contract Documents shall create any contractual relation between the Owner and any Subcontractor or Sub-subcontractor.

5.1.4 The Owner retains the right and privilege to reject any Subcontractor or Sub-subcontractor and further retains the right and privilege to approve any and all Subcontractors or Sub-subcontractors.

## 5.2 AWARD OF SUBCONTRACTS AND OTHER CONTRACTS FOR PORTIONS OF THE WORK

5.2.1 The Supplementary Conditions include a requirement for the identification of specified Subcontractors.

5.2.2 The Contractor shall not make any substitution for any Subcontractor or person or organization who has been accepted by the Owner and the Architect, unless the substitution is acceptable to the Owner (per Florida Statute 255.0515).

## 5.3 SUBCONTRACTUAL RELATIONS

5.3.1 All work performed for the Contractor by a Subcontractor shall be pursuant to an appropriate agreement between the Contractor and the Subcontractor (and where appropriate between Subcontractor and Sub-subcontractors) which shall contain provisions that:

5.3.1.1 preserve and protect the rights of the Owner and the Architect under the Contract with respect to the Work to be performed under the subcontract so that the subcontracting thereof will not prejudice such rights;

5.3.1.2 require that such work be performed in accordance with the requirements of the Contract Documents;

5.3.1.3 required submission to the Contractor of applications for payment under each subcontract to which the Contractor is a party, in reasonable time to enable the Contractor to apply for payment in accordance with Article 9;

5.3.1.4 required that all claims for additional costs, extensions of time, damages for delays or otherwise with respect to subcontracted portions of the Work shall be submitted to the Contractor (via any Subcontractor or Sub-subcontractor where appropriate) in sufficient time so that the Contractor may comply in the manner provided in the Contract Documents for like claims by the Contractor upon the Owner;

5.3.1.5 waive all rights the contracting parties may have against one another for damages caused by fire or other perils covered by the property insurance described in the Supplementary Conditions, Paragraph 8, except such rights as they may have to the proceeds of such insurance held by the Contractor as trustee under Paragraph 11.1 and

5.3.1.6 obligate each Subcontractor specifically to consent to the provisions of this Paragraph 5.3.

#### 5.4 PAYMENT TO SUBCONTRACTORS

5.4.1 The Contractor shall pay each Subcontractor, upon receipt of payment from the Owner, an amount equal to the percentage of completion allowed to the Contractor on account of such Subcontractor's Work, less the percentage retained from payment to the Contractor. The Contractor shall also require each Subcontractor to make similar payment to his Sub-subcontractors.

5.4.2 If the Architect fails to issue a Certificate for Payment for any cause which is the fault of the Contractor and not the fault of a particular Subcontractor, the Contractor shall pay the Subcontractor on demand, made at any time after the Certificate for Payment should otherwise have been issued, for his Work to the extent completed, less the retained percentage.

5.4.3 The Contractor shall pay each Subcontractor a just share of any insurance monies received by the Contractor under Article 2, and he shall require each Subcontractor to make similar payment to his Sub-subcontractors.

5.4.4 The Architect may, on request and at his discretion, furnish to any Subcontractor, if practicable, information regarding percentage of completion certified to the Contractor on account of Work done by such Subcontractors.

5.4.5 Neither the Owner nor the Architect shall have any obligation to pay or to see to the payment of any monies to any Subcontractor except as may otherwise be required by law.

5.4.6 Subcontractors, forty-five (45) days after satisfactory completion of their work on the Contractor's project, can invoice the Contractor for the remainder of unpaid work, including the full value of the retainage related to their work, less the value of any item contested in accordance with the terms and conditions of the construction contract. The Subcontractor shall include a partial release of lien and all appropriate warranties and closeout documentation with this final payment invoice to the Contractor. The Contractor must include this subcontractor payment request in the next Application for Payment in the pay application cycle to the Architect following the receipt of the subcontractor payment request, if deemed to be complete and in compliance with this section. The owner shall process the payment request within 20 days of receipt of the Certificate for Payment from the Architect, and shall include payment of the retainage, less the value of any contested item, in its next payment to the Contractor. When a Contractor receives payment from the Owner for labor, services, or materials furnished by subcontractors and suppliers hired by the Contractor, the Contractor shall remit payment due to those subcontractors and suppliers, less the value of any item contested in accordance with the terms and conditions of the construction Contract, within ten (10) days after the Contractor's receipt of payment.

When the Contractor receives payment from the Owner for labor, services, or materials furnished by subcontractors and suppliers hired by the Contractor for the project, the Contractor shall remit payment due to those subcontractors and suppliers, less the value of any item contested in accordance with the Contract, within 10 days after the Contractor's receipt of payment from the Owner. When the payment due the subcontractor is for final payment, including retainage, the subcontractor must include with the invoice for final payment a conditional release of lien and all appropriate warranties and close out documentation. When the subcontractor receives payment from the Contractor for labor, services, or materials furnished by subcontractors and suppliers hired by the subcontractor, the subcontractor shall remit payment due to those subcontractors and suppliers, less the value of any item contested in accordance with the Contract, within ten (10) days after the subcontractor's receipt of payment.

This provision shall not be construed to create a contractual relationship of any kind (1) between the Architect and Contractor, (2) between the Owner and Subcontractor of Sub-subcontractor (et al.), (3) between the Owner and Architect or (4) between any persons or entities other than the Owner and Contractor.

**ARTICLE 6.00  
SEPARATE CONTRACTS**

6.1            **OWNER'S RIGHT TO AWARD SEPARATE CONTRACTS**

6.1.1        Prior to and during the progress of the Work, the Owner reserves the right to award other contracts relating to the Project or in connection with other work within the boundaries of the Project.

6.1.2        When separate contracts are awarded for different portions of the Project, "the Contractor" in the Contract Documents in each case shall be the contractor who signs each separate contract.

6.2            **MUTUAL RESPONSIBILITY OF CONTRACTORS**

6.2.1        The Architect shall coordinate the Work of the Contractor with that of other Contractors on the site. The Contractor shall cooperate fully with the Architect in this activity and shall afford other Contractors reasonable opportunity for the introduction and storage of their materials and equipment and the execution of their Work, and shall properly connect and coordinate his Work with theirs.

6.2.2        If the project will be constructed using phased design and construction methods, the Work of the Contractor will depend upon proper execution and results of the Work of another Contractor.

The Contractor shall inspect and promptly report to the Architect any apparent discrepancies or defects in such Work that render it unsuitable for such proper execution and results. Failure of the Contractor to inspect and report shall constitute an acceptance of the other Contractor's Work as fit and proper to receive his Work, except as to defects which may develop in the other separate Contractor's Work after the execution of the Contractor's Work.

6.2.3        Should the Contractor cause damage to the Work or property of any separate Contractor on the Project, the Contractor shall, upon due notice, settle with such other Contractor by agreement or arbitration, if he will so settle. If such separate Contractor sues the Owner or initiates an arbitration proceeding on account of any damage alleged to have been so sustained, the Owner shall notify the Contractor who shall defend such proceedings, and if any judgment or award against the Owner arises therefrom the Contractor shall pay or satisfy it and shall reimburse the Owner for all attorney's fees and court or arbitration costs which the Owner has incurred.

**ARTICLE 7.00  
MISCELLANEOUS PROVISIONS**

7.1            **GOVERNING LAW**

7.1.1        The Contract shall be governed by the law of the State of Florida and all local ordinances and codes.

7.2            **SUCCESSORS AND ASSIGNS**

7.2.1        The Owner and the Contractor each binds himself, his partners, successors, assigns and legal representatives to the other party hereto and to the partners, successors, assigns and legal representatives of such other party in respect to all covenants, agreements and obligations contained in the Contract Documents. Neither party to the Contract shall assign the Contract or sublet it as a whole without the written consent of the other, nor shall the Contractor assign any monies due or to become due to him hereunder, without the previous written consent of the Owner.

7.3            **WRITTEN NOTICE**

7.3.1        Written notice shall be deemed to have been duly served if delivered in person to the individual or member of the firm or to an officer of the corporation for whom it was intended, or if

delivered at or sent by registered or certified mail to the last business address known to him who gives the notice.

#### 7.4 CLAIMS FOR DAMAGES

7.4.1 Should either party to the Contract suffer injury or damage to person or property because of any act or omission of the other party or of any of his employees, agents or others for whose acts he is legally liable, claim shall be made in writing to such other party within a reasonable time after the first observance of such injury or damage.

#### 7.5 PERFORMANCE BOND AND LABOR AND MATERIAL PAYMENT BOND

7.5.1 Performance Bond and Labor and Material Payment Bond, in the penal sum of not less than 100 percent of the Contract amount, with a Surety Company satisfactory to the Owner and licensed to conduct business in the State of Florida, will be required of the Contractor for any resulting contract in excess of \$200,000 guaranteeing that the Contract, including the various guarantee periods thereunder, will be faithfully performed; and that the Contractor will promptly make payment to all persons supplying him labor, materials, supplies and services used directly or indirectly by the Contractor in the prosecution of the Work provided for in the Contract. The Bonds, along with the appropriate power of attorney, shall be delivered to the Owner simultaneously with Contractor's execution of the Agreement. The Bonds shall extend as a Guarantee Bond for one (1) year after acceptance of the Project.

7.5.2 In the event that Surety Company becomes bankrupt, insolvent or unsatisfactory to the Owner, the Contractor shall substitute additional or new Bonds in the same or lesser penal sum, satisfactory to the Owner and to be conditioned as above required. Upon the Contractor's failure to furnish such additional or new Bonds within five (5) days from the date of written notice to do so, all payments under this Contract shall be withheld until such additional Bonds are furnished.

7.5.3 The Bonds required in Paragraphs 7.5.1 and 7.5.2 shall be executed on A1A Form A311, and, prior to delivery to the Owner, shall be recorded in the public records of the county where the work is to be performed pursuant to FS 255.05(1)(a).

#### 7.6 RIGHTS AND REMEDIES

7.6.1 The duties and obligations imposed by the Contract Documents and the rights and remedies available thereunder shall be in addition to and not a limitation of any duties, obligations, rights and remedies otherwise imposed or available by law.

#### 7.7 ROYALTIES AND PATENTS

7.7.1 The Contractor shall pay all royalties and license fees. He shall defend all suits or claims for infringement of any patent rights and shall save the Owner harmless from loss on account thereof, except that the Owner shall be responsible for all such loss when a particular design, process or the product of a particular manufacturer or manufacturers is specified, but if the Contractor has reason to believe that the design, process or product specified is an infringement of a patent, he shall be responsible for such loss unless he promptly gives such information to the Architect.

#### 7.8 TESTS

7.8.1 If the Contract Documents, laws, ordinances, rules, regulations or orders of any public authority having jurisdiction require any Work to be inspected, tested or approved, the Contractor shall give the Architect timely notice of its readiness and of the date arranged so the Architect may observe such inspection, testing or approval. The Contractor shall bear all costs of such inspections, tests, and approvals unless otherwise provided.

7.8.2 If after the commencement of the Work the Architect determines that any Work requires special inspection, testing, or approval which subparagraph 7.8.1 does not include, he will, upon written

authorization from the Owner instruct the Contractor to order such special inspection, testing or approval, and the Contractor shall give notice as in subparagraph 7.8.1. If such special inspection or testing reveals a failure of the Work to comply (1) with the requirements of the Contract Documents or (2), with respect to the performance of the Work, with laws, ordinances, rules, regulations or orders of any public authority having jurisdiction, the Contractor shall bear all costs thereof, including the Architect's additional services made necessary by such failure; otherwise the Owner shall bear such costs and an appropriate Change Order shall be issued.

7.8.3 Required certificates of inspection, testing or approval shall be secured by the Contractor and promptly delivered by him to the Architect.

7.8.4 If the Architect wishes to observe the inspections, tests or approval required by this Paragraph 7.8 he will do so promptly and, where practicable, at the source of supply.

7.8.5 Neither the observations of the Architect in his administration of the Construction Contract, nor inspections, tests or approvals by persons other than the Contractor shall relieve the Contractor from his obligations to perform the Work in accordance with the Contract Documents.

7.8.6 The State Board Of Education requirements adopted pursuant to Chapter 120 FS to implement the State Uniform Building Code for Public Educational Facilities Construction in Chapter 1013, FS, are contained in Section 423 of the Florida Building Code and the Department of Education publication "State Requirements for Educational Facilities 2012" Plan Reviews and Building Inspections or the most current in accordance with the Florida Building Code will be performed by the College to ensure compliance with Florida State Statutes. Qualified individuals will be properly assigned to each project and properly licensed to perform these tasks. The College Staff is to assume neither the contractor's responsibility for the project nor the Architect's/Engineer's responsibility for the design or contract administration of the contract documents or project.

7.867 Pensacola State College issues its own Building Permits and performs its own Building Inspections in accordance with the Florida Building Code. Currently there is no charge to the Contractor for the Building Permit, Project Plan Review or the Building Inspections. The quantity and types of project inspections are job specific in the general areas of Demolition, Building, Plumbing, Heating and Air Conditioning, Fire Protection, and Civil. It is the Contractor's responsibility to request all inspections.

## 7.9 EQUALITY AND SUBSTITUTIONS

7.9.1 In general, the preparation of the Drawings and Specifications has been based upon sizes, loads, and requirements of specific items of materials or equipment and, as such, it is the basis of bidding without exception. Therefore, all substitutions must be in accordance with the following provision:

7.9.2 In all instances where a particular system, product, or material is identified by one or more brand or trade names, one of such systems, products or materials, at the option of the bidder, shall be considered as the basis for bidding. Should a bidder wish to propose an equivalent system, product or material of a different manufacturer, he should submit a request, accompanied by substantiating technical data to the Architect at least ten (10) days prior to the date set for receipt of bids. If the proposed equivalent is acceptable to the College such will be acknowledged in an Addendum. If an addendum is not issued, bids submitted shall be in strict adherence to the specifications

## 7.10 PRECONSTRUCTION CONFERENCE

7.10.1 Before starting any construction work on the project, a conference including the Architect will be held at a place as designated by the Owner and coordinating with the Architect for the purpose of verifying general procedures, expediting and handling of Shop Drawings and Schedules and to establish a working understanding between the parties concerned with this project.

Present at the conference shall be a responsible representative of the Contractor, the Contractor's Job Superintendent and representatives of the Architect and Owner. If Contractor so desires, he may have present with him representatives of major subcontractors. The date and time of the conference shall be agreed upon by the Owner, Contractor and Architect.

#### 7.11 REFERENCED SPECIFICATIONS AND DOCUMENTS

7.11.1 Documents, materials, systems or operations specified by reference shall be provided in compliance with the requirements of the specified reference, except as modified by the requirements of the Contract Documents. Unless a particular edition is called for, the reference used shall be the latest published edition on the date of the Project Specifications.

7.11.2 In case of conflict between references and the Project Specifications, the Project Specifications shall govern. In case of conflict between references, the references having the more stringent requirement shall govern.

### ARTICLE 8.00 TIME

#### 8.1 DEFINITIONS

8.1.1 The Contract Time is the period of time allotted for completion of the Work.

8.1.2 The date of commencement of Work is the date established in the Notice to Proceed.

8.1.2.1 If there is no Notice to Proceed, commencement of the Work shall be the date of the Purchase Order or Contract or such date as may be established therein.

8.1.3 The Date of Substantial Completion of the Work or designated portion thereof is the Date certified by the Architect when construction is sufficiently complete, in accordance with the Contract Documents, so the Owner may occupy the Work or designated portion thereof for the use for which it is intended.

8.1.4 The term day as used in the Contract Documents shall mean calendar day.

#### 8.2 PROGRESS AND COMPLETION

8.2.1 All time limits stated in the Contract Documents are of the essence of the Contract.

8.2.2 **It is anticipated the project will be awarded on or before November 22, 2013. Work must be completed by December 31, 2013.**

#### 8.3 DAMAGES FOR DELAY

8.3.1 Where the College and the Contractor cannot agree that the delay in the prosecution of the Work is justified, liquidated damages will be assessed in the amount of \$400.00 per calendar day of delay until work is substantially completed. After substantial completion, justified liquidated damages will be assessed in the amount of \$200.00 per calendar day of delay until work is rendered at final completion.

### ARTICLE 9.00 PAYMENTS AND COMENSATION

#### 9.1 CONTRACT SUM

9.1.1 The Contract Sum is stated in the Proposal and is the total amount payable by the Owner to the Contractor for the performance of the Work under the Contract Documents.

#### 9.2 SCHEDULE OF VALUES

9.2.1 Within two (2) weeks after the Contract is executed, the Contractor shall submit to the Architect a schedule of values of the various portions of the Work, including quantities aggregating the

total Contract Sum, divided so as to facilitate payments to Subcontractors in accordance with Paragraph 5.4 prepared on Attachment Two (2), Schedule of Values and Work in Place, as the Architect and the Contractor may agree upon, and supported by such data to substantiate its correctness as the Architect may require. Each item in the schedule of values shall include its proper share of overhead and profit. This schedule when approved by the Architect shall be used only as a basis for the Contractor's Applications for Payment.

### 9.3 PROGRESS PAYMENTS

9.3.1 Not less than thirty (30) days after the previous application, the Contractor shall submit to the Architect an itemized Application for Payment, supported by such data substantiating the Contractor's right to payment on Attachment Three (3) to these General Conditions, an original and three (3) copies shall be forwarded to the Architect for distribution as follows: Owner, original and two (2) copies; Architect, one (1) copy.

9.3.2 At the discretion of the Owner payment will be made on account of materials and equipment not incorporated in the Work but delivered and suitably stored at the site or at some other location agreed upon in writing. Such payments shall be conditioned upon submission by the Contractor of bills of sale or such other procedures satisfactory to the Owner to establish the Owner's title to such materials and equipment or otherwise protect the Owner's interest including applicable insurance and transportation to the site.

9.3.3 The Contractor warrants and guarantees that title to all Work, materials and equipment covered by an Application for Payment, will pass to the Owner upon receipt of such payment by the Contractor, free and clear of all liens, claims, security interest or encumbrances, hereinafter referred to in this Article 9 as "Liens"; and that no Work, materials or equipment covered by an Application for Payment will have been acquired by the Contractor or by any other person performing the Work at the site or furnishing materials and equipment for the Project, subject to an agreement under which an interest therein or an encumbrance thereon is retained by the seller or otherwise imposed by the Contractor or such other person.

### 9.4 CERTIFICATES FOR PAYMENT

9.4.1 If the Contractor has made Application for Payment as above, the Architect will, with reasonable promptness but not more than seven days after the receipt of the Application, issue a Certificate for Payment to the Owner, with a copy to the Contractor, for such amount as he determines to be properly due, or state in writing his reasons for withholding a Certificate as provided in Subparagraph 9.5.1.

9.4.2 The issuance of a Certificate for Payment will constitute a representation by the Architect to the Owner, based on his observations at the site as provided in Subparagraph 2.2.4 and the data comprising the Application for Payment, that the Work has progressed to the point indicated; that, to the best of his knowledge, information and belief, the quality of the Work is in accordance with the Contract Documents (subject to an evaluation of the Work for conformity with the Contract Documents Substantial Completion, to the results of any subsequent tests required by the Contract Documents correctable prior to completion, and to any specific qualifications stated in his Certificate); and that the Contractor is entitled to payment in the amount certified. In addition, the final Certificate for Payment will constitute a further representation the conditions precedent to the Contractor's being entitled to final payment as set forth in Subparagraph 9.7.2 have been fulfilled. However, by issuing a Certificate for Payment, the Architect shall not thereby be deemed to represent that he has made any examination to ascertain how or for what purpose the Contractor has used the monies previously paid on account of the Contract Sum.

9.4.3 After the Architect has issued a Certificate for Payment, the Owner shall make payment in the manner provided in the Agreement.



9.4.4 No certificate for a progress payment, nor any progress payment, nor any partial or entire use or occupancy of the Project by the Owner, shall constitute an acceptance of any Work not in accordance with the Contract Documents.

## 9.5 PAYMENTS WITHHELD

9.5.1 The Architect may decline to approve an Application for Payment and may hold his Certificate in whole or in part, to the extent necessary reasonably to protect the Owner, if in his opinion he is unable to make representations to the Owner as provide in Subparagraph 9.4.2. The Architect may also decline to approve any Applications for Payment, or, because of subsequently discovered evidence or subsequent inspections, he may nullify the whole or any part of any Certificate for Payment previously issued, to such extent as may be necessary in his opinion to protect the Owner from loss because of:

9.5.1.1 defective Work not remedied or completed Work that has been damaged requiring correction or replacement,

9.5.1.2 third party claims have been filed or there is reasonable cause to believe such will be filed,

9.5.1.3 reasonable evidence of the failure of the Contractor to make payments properly to Subcontractors for labor, materials or equipment,

9.5.1.4 reasonable doubt that the Work can be completed for the unpaid balance of the Contract Sum,

9.5.1.5 damage to another contractor,

9.5.1.6 reasonable indication that the Work will not be completed within the Contract Time, (withholding sufficient funds to cover the anticipated assessment of liquidated damages), or

9.5.1.7 unsatisfactory prosecution of the Work including failure to furnish acceptable submittals and adhere to the provision of the Special Conditions appended hereto.

9.5.2 When the above grounds in Subparagraph 9.5.1 are removed, payment shall be made for amounts withheld because of them.

## 9.6 SUBSTANTIAL COMPLETION

9.6.1 When the Contractor determines that the Work or a designated portion thereof acceptable to the Owner is substantially complete, the Contractor shall give written notice of such to the Architect. When the Architect determines by an inspection that the Work is substantially complete, he will then prepare a Certificate of Substantial Completion which shall establish the Date of Substantial Completion; shall state the responsibilities of the Owner and the Contractor for maintenance, heat, utilities, and insurance, and shall fix the time within which the Contractor shall complete any remaining work shown therein. The Certificate of Substantial Completion shall be submitted to the Owner and the Contractor for their written acceptance of the responsibilities assigned to them in such certificate.

9.6.2 The Contractor shall cooperate with the Owner if it is the Owner's desire to occupy a substantially completed structure or portion of a structure. When such occupancy takes place the applicable warranty periods for the occupied portion shall be as provided in the Certificate of Substantial Completion.

9.6.3 The assessment of liquidated damages, if any, shall terminate on the Date of Substantial Completion.

## 9.7 FINAL PAYMENT

9.7.1 Upon receipt of written notice from the Contractor that the Work is complete and ready for final inspection and acceptance, the Architect will make a final inspection and will notify the Contractor in writing of all particulars in which this inspection reveals the work to be incomplete or defective. The Contractor shall immediately take such measures as are necessary to remedy such deficiencies.

9.7.2 After the Contractor has corrected all deficiencies and delivered all Maintenance and Operating Instructions, Record Drawings, Guarantees, Bonds, Certificates of Inspection and other documents - all as required by the Contract Documents, he may make Application for Final Payment following the procedure for progress payments. The Application for Final Payment must be accompanied, in addition to the supporting data and schedules submitted with progress payments, by submittals as follows: (a) An Affidavit, sufficient to establish compliance with the provisions of the Mechanics Lien Law (Chapter 713 - Florida Statutes), stating, if that be the fact, that all lienors have been paid in full, or if the fact be otherwise, showing the name of each lienor who has not been paid in full and the amount scheduled to become due each for labor, services, or materials furnished; (b) Consent of surety, if any, to final payment; and (c) If required by the Owner, other data establishing payment or satisfaction of all obligations, such as receipts, releases, and waivers of liens arising out of the Contract to the extent and in such form as designated by the Owner. If any Subcontractor, material man, fabricator or supplier fails or refuses to furnish a release or waiver in full the Contractor will furnish a Bond or other collateral satisfactory to the Owner to indemnify him against any lien. If any lien remains unsatisfied after all payments are made, the Contractor shall refund to the Owner all monies that the latter may be compelled to pay in discharging such lien, including all costs and reasonable attorneys' fees.

9.7.3 If, on the basis of his observation and review of the Work during construction, his final inspection, and his review of the final Application for Payment - all as required by the Contract Documents, The Architect is satisfied that the Work has been completed and the Contractor has fulfilled all his obligations under the Contract Documents, he will within ten (10) days after receipt of the final Application for Payment, indicate in writing his approval thereof and issue a final Certificate of Payment to the Owner. Thereupon the Architect will give written notice to the Owner and the Contractor that the work is acceptable subject to the provisions of Paragraph "Waiver of Claims". Otherwise he will return the application to the Contractor, indicating in writing his reasons for refusing to approve final payment, in which case the Contractor will make the necessary corrections and resubmit the application. The Owner will within thirty (30) days after receipt by him of both an approved final Certificate of Payment from the Architect and an approved Certificate of Final Inspection by the Florida Department of Education pay the Contractor the full amount of the Contract Sum, less the aggregate of all previous payments and any assessment of liquidated damages.

9.7.4 The making of final payment shall constitute a waiver of all claims by the Owner except those arising from:

9.7.4.1 unsettled claims,

9.7.4.2 faulty or defective Work appearing after Substantial Completion,

9.7.4.3 failure of the Work to comply with the requirements of the Contract Documents, or

9.7.4.4 terms of any special guarantees required by the Contract Documents.

9.7.5 The acceptance of final payment shall constitute a waiver of all claims by the Contractor except those previously made in writing and still unsettled.

9.8 MISCELLANEOUS PROVISIONS

9.8.1 Unless otherwise provided or agreed upon, the amount certified for payment on each certificate, except the final payment certificate, shall ninety percent (90%) of the amount approved under Article 9.4.2 less previous amounts certified for payment until 50-percent completion has been achieved substantial completion.

9.8.11 At substantial completion, ninety five percent (95%) of the amount certified for payment on each certificate, with retainage reduced to five percent (5%) upon request with proper documentation.

**ARTICLE 10.00  
PROTECTION OF PERSONS AND PROPERTY**

10.1 SAFETY PRECAUTIONS AND PROGRAMS

10.1.1 The Contractor shall be responsible for initiating, maintaining and supervising all safety precautions and programs in connection with the Work.

10.2 SAFETY OF PERSONS AND PROPERTY

10.2.1 The Contractor shall take all reasonable precautions for the safety of, and shall provide all reasonable protection to prevent damage, injury or loss to:

10.2.1.1 all employees on the Work and all other persons who may be affected thereby;

10.2.1.2 all the Work and all materials and equipment to be incorporated therein, whether in storage on or off the site, under the care, custody or control of the Contractor or any of his Subcontractors or Sub-subcontractors and;

10.2.1.3 other property at the site or adjacent thereto including trees, shrubs, lawns, walks, pavements, roadways, structures and utilities not designated for removal, relocation or replacement in the course of construction.

10.2.2 The Contractor shall comply with all applicable laws, ordinances, rules, regulations and lawful orders of any public authority having jurisdiction for the safety of persons or property or to protect them from damage, injury or loss. He shall erect and maintain as required by existing conditions and progress of the Work, all reasonable safeguards for safety and protection, including posting danger signs and other warnings against hazards, promulgating safety regulations and notifying owners and users of adjacent utilities.

10.2.3 When the use or storage of explosives or other hazardous materials or equipment is necessary for the execution of the Work, the Contractor shall exercise the utmost care and shall carry on such activities under the supervision of properly qualified personnel.

10.2.4 All damage or loss to any property referred to in Clauses 10.2.1.2 and 10.2.1.3 caused in whole or in part by the Contractor, any Subcontractor, any Sub-subcontractor, or anyone directly or indirectly employed by any of them, or by anyone for whose acts any of them may be liable, shall be remedied by the Contractor, except damage or loss attributable to faulty Drawings or Specification or to the acts or omissions of the Owner or Architect or anyone employed by either of them or for whose acts either of them may be liable, and not attributable to the fault or negligence of the Contractor.

10.2.5 The Contractor shall designate a responsible member of his organization at the site whose duty shall be the prevention of accidents. This person shall be the Contractor's superintendent unless otherwise designated in writing by the Contractor to the Owner and the Architect.

10.2.6 The Contractor shall not load or permit any part of the Work to be loaded so as to endanger its safety.

### 10.3 EMERGENCIES AND SAFETY

10.3.1 In any emergency affecting the safety of persons or property, the Contractor shall act, at his discretion, to prevent threatened damage, injury or loss. Any additional compensation or extension of time claimed by the Contractor on account of emergency work shall be determined as provided in Article 12 for Changes in the Work.

10.3.2 The Contractor by submitting a bid response agrees that it shall be solely responsible for supervising its employees, that it shall comply with all rules, regulations, orders, standards and interpretations promulgated pursuant to the Occupational Safety and Health Act of 1970, including but not limited to training, recordkeeping, providing personal protective equipment, lockout/tagout procedures, Material Safety Data Sheets and labeling as required by the right to know standard, 29 CFR 1910.1200.

## **ARTICLE 11.00 INSURANCE**

### 11.1 CONTRACTOR'S LIABILITY INSURANCE

Pursuant to Senate Bill 50A and FS Chapter 440: During the Contract term, the Contractor at its sole expense shall provide commercial insurance of such a type and with such terms and limits as may be reasonably associated with the Contract, which, at a minimum, shall be: Workers' Compensation And Employer's Liability insurance in accordance with Chapter 440 of the Florida Statutes with minimum Employers' Liability limits of \$100,000 per accident per person, and \$500,000 policy aggregate. Such policy shall cover all employees engaged in any Contract work.

Pursuant to Florida Statutes, effective 1/1/2004 employers who have employees who are engaged in work in Florida must use Florida rates, rules and classifications for those employees. In the construction industry, only corporate officers of a corporation or any group affiliated corporations may elect to be exempt from workers' compensation coverage requirements. Such exemptions are limited to a maximum of three per corporation and each exemption holder must own at least 10% of the corporation. Independent contractors, sole proprietors and partners in the construction industry cannot elect to be exempt and must maintain worker' compensation insurance.

11.1.1 The awarded Contractor shall purchase and maintain with a company or companies licensed to do business in the State of Florida and acceptable to the Owner and his Risk Manager such insurance as will protect him from claims, some of which are set forth below, which may rise out of or result from the Contractor's operations under the Contract, whether such operations be by himself or by any Sub-contractor or by anyone directly or indirectly employed by any of them, or by anyone else for whose acts any of them may be liable. The specific delineation of coverage in this paragraph is a minimum guide only, it being the specific intent of the Owner that it shall be fully and completely protected and indemnified from any and all claims which may arise out of Contractor's operation under the Contract; including among others those checked below:

claims under workers' compensation, disability benefit and other similar employee benefit acts;  
claims for damages because of bodily injury, occupational sickness or disease, or death of this employees;

claims for damages because of bodily injury, sickness or disease, or death of any person other than his employees;

claims for damages by usual personal injury coverage including but not limited to libel, slander, and false arrest which are sustained (1) by any person including, but not limited to, a Contractor, Subcontractor or Sub-subcontractor or their employees as a result of an occurrence directly or indirectly related to the employment of such person by the Contractor, or (2) by any other person;

claims for damages because of injury to or destruction of tangible property, including loss of use resulting therefrom;

claims resulting from explosion, collapse, or underground accident, (X-C- U coverage required) and other on-premises operations.

claims resulting from owned, hired and non-owned motor vehicles and equipment;

claims for damage resulting from the actions or inactions of independent Contractors;

claims arising under products and completed operations insurance.

11.1.2 The insurance required by Subparagraph 11.a) shall be written for not less than the limits of liability specified below, or required by law, whichever is greater, and shall include contractual liability insurance as applicable to the Contractor's obligations under Paragraph 4.17 in the General Conditions.

A - Workers' Compensation Coverage per Florida Statutes including All States  
Endorsement

B - Employers' Liability:

\$100,000.00	Limit Per Accident
\$500,000.00	Disease Policy Limit
\$100,000.00	Limit for Employee

Comprehensive Automobile Liability - including  
Employers' Non-Ownership and Hired Car Coverage:

\$ 1,000,000.00 combined Single Limit for Bodily Injury and Property Damage.

Comprehensive General Liability Coverage \$ 1,000,000.00 combined Single Limit for Bodily and Personal Injury and Property Damage. This insurance shall name the District Board of Trustees of Pensacola State College as an additional insured.

Commercial General Liability Coverage - Occurrence Form Required

Coverage A shall include bodily injury and property damage liability for premises, operations, products and completed operations, independent contractors, contractual liability covering this agreement, contract or lease, broad form property damage, and property damage resulting from explosion, collapse or underground (x,c,u) exposures.

Coverage B shall include personal injury. Coverage C, medical payments, is not required.

Excess umbrella liability \$2,000,000 per occurrence and in the aggregate.

Coverage to be certified by the Contractor (and their Subcontractors) shall include, but not be limited to the following:

- Workers' Compensation
- Automobile owned, hired and non-owned
- Premises
- Operations
- Contractual
- Personal injury - Hazards, A, B and C with employee exclusion removed
- Broad Form Property Damage
- Removal of X, C and U exclusions
- Products and Completed Operations
- Independent Contractors

11.2.3 A Certificate of Insurance, executed on a standard ACORD form, shall be filed with the Owner simultaneously with the Contractor's execution of the Agreement. The certificate shall contain a provision that coverages afforded under the policies will not be cancelled until at least thirty (30) days prior written notice has been given to the Owner. The Certificate of Insurance will include the following statement: "Interest of the Certificate Holder is included as an Additional Insured."

## 11.2 PROPERTY INSURANCE

11.2.1 Until the Work is completed and accepted by the Owner, the contractor shall purchase and maintain property insurance upon the entire Work at the site to the full insurable value thereof. This insurance shall include the interest of the Owner, the Contractor, Subcontractors and Sub-subcontractors in the Work and shall on an all risk special form. Coverage shall include damages, losses, and expenses arising out of or resulting from any insured property including fees and charges of Architects, Engineers and Attorneys.

11.2.2 The Contractor shall purchase and maintain such steam boiler and machinery insurance as may be required by the Contract Documents or by law. The insurance shall include the interest of the Owner, the Contractor, Subcontractors and Sub-subcontractors in the Work.

11.2.3 The Contractor shall file a copy of all policies with the Owner before an exposure to loss may occur, but not later than the first Application for Payment.

11.2.4 The Owner and Contractor waive all rights against each other or damages caused by fire or other perils to the extent covered by insurance provided under this Paragraph, except such rights as they may have to the proceeds of such insurance held by the Owner as trustee. The Contractor shall require similar waivers by Subcontractors and Sub-subcontractors in accordance with Clause 5.3.1.5. In waiving rights of recovery under terms of this Paragraph the term "Owner" shall be deemed to include his employees and the Architect, and its employees as the Owner's representative.

## **ARTICLE 12.00 CHANGES IN WORK**

### 12.1 CHANGE ORDERS

12.1.1 The Owner, without invalidating the Contract and without notice to the sureties, may order Changes in the Work within the General scope of the Contract consisting of additions, deletions or other revisions, the Contract Sum and the Contract Time being adjusted accordingly. All such Changes in the Work shall be authorized by Change Order, and shall be executed under the applicable conditions of the Contract Documents.

12.1.2 A Change Order is a written order to the Contractor signed by the Owner and the Architect, issued after the execution of the Contract, authorizing a Change in the Work or an

adjustment in the Contract Sum or the Contract Time. A Change Order will also be signed by the Contractor if he agrees to the adjustment on the Contract Sum or the Contract Time. The Contract Sum and the Contract Time may be changed only by Change Order.

12.1.3 The cost or credit to the Owner resulting from a Change in the Work shall be determined in one or more of the following ways:

12.1.3.1 by mutual acceptance of a lump sum properly itemized;

12.1.3.2 by unit prices stated in the Contract Documents or subsequently agreed upon; or

12.1.3.3 by cost and a mutually acceptable fixed or percentage fee.

12.1.4 If none of the methods set forth in 12.1.3 is agreed upon and the Owner and Architect deem it necessary that the added work in question be performed without delay, the Contractor shall promptly proceed with the added work in question. The cost of such Work shall then be determined by the Architect on the basis of the Contractor's reasonable expenditures and savings, including, in the case of an increase in the Contract Sum, a reasonable allowance for overhead and profit. In such case, and also under Clause 12.1.3.3 above the Contractor shall keep and present in such form as the Architect may prescribe, an itemized accounting together with appropriate supporting data. Pending final determination of cost to the Owner, payments on account shall be made on Certificate for Payment approved by the Architect. The amount of credit to be allowed by the Contractor to the Owner for any deletion or change which results in a net decrease in cost will be the amount of the actual net decrease as confirmed by the Architect. When both additions and credits are involved in any one change, the allowance for overhead and profit shall be figured on the basis of net amount, if any. Change Orders extending Contract Time for completion will not automatically entitle the Contractor to increased costs for overhead during the extended period unless specifically allowed in the Change Order.

12.1.5 If the Architect, the Owner and the Contractor agree that the unit costs set forth in the Contract Documents are not applicable to the quantities of added work in question, they shall not be utilized.

12.1.6 If the Contractor claims that additional cost is involved because of (1) any written interpretation issued pursuant to Subparagraph 1.2.8, (2) any order by the Owner to stop the Work pursuant to Paragraph 3.3 where the Contractor was not at fault, or (3) any written order for a minor change in the Work issued pursuant to Paragraph 12.3, the Contractor shall make such claim as provided in Paragraph 12.2.

12.1.7 When the amount of cost or credit is to be based on mutual acceptance of a lump sum (Clause 12.1.3.1), whether such an amount is an extra, a credit, or no- change-in-contract price, the Contractor shall submit a change order estimate on forms furnished by the Owner which shall be substantiated by a complete itemized breakdown (including breakdowns from each Subcontractor on the same form) showing all direct costs for the change or changes in the Work. The breakdown shall list quantities and unit prices for materials, labor, equipment and other items of cost when the amount of cost is to be based on actual direct cost plus overhead and profit (Clause 12.1.3.3). The Contractor shall submit receipts or other evidence as the Architect may direct, showing actual direct costs and his right to the payment claimed.

12.1.8 The following factors shall be applicable to all methods of arriving at extra or credit for Change Orders except where unit prices (Clause 12.1.3.2) are stated in the Contract Documents:

12.1.8.1 for all Work done by his own organization, the Contractor may add ten percent (10%) of his net increase in direct costs for combined overhead and profit;

12.1.8.2 for all change order Work done by Subcontract, the contractor may add ten percent (10%) of the net increase in direct costs for combined overhead and profit above Subcontractor's direct cost for his overhead and profit (as defined herein).

12.1.8.3 where changes involve the Contractor and one or more Subcontractors, the breakdown shall itemize the above percentages separately, by use of individual change order estimate forms;

12.1.8.4 overhead and profit percentages will be deducted on items which have a net decrease;

12.1.8.5 when both additions and deductions are involved in any one item, the overhead and profit shall apply to the net amount, if any;

12.1.8.6 subcontractor direct costs shall include labor, materials, Worker's Compensation, taxes, health and retirement benefits, social security, and the expense of work performed after regular working hours to the extent authorized by the Owner;

12.1.8.7 contractor supervision, clean-up services, insurance, contractor incremental performance and payment bond cost, proportionate necessary transportation, traveling and subsistence expenses of Contractor's employees incurred for the Project; materials, supplies and temporary facilities, including Project office expenses; equipment rental by agreement approved by Owner with advice of Architect, including transportation and unloading; telegrams, postage, telephone service at the site and other normal overhead expenses as approved by Owner shall be included in the Contractor's 10% compensation for overhead and profit. Contractor is authorized on change orders to submit for reimbursement incremental pre-approved dumpster rental at cost. Contractor is not authorized to invoice the College for subcontractor performance and payment bond cost as Florida statutes only require the contractor to bond the College for work > \$200,000.00.

12.1.9 The above added percentages are defined to include all overhead and additional costs resulting from the change in scope of work including any time extensions.

12.1.10 Notwithstanding any other provisions of this Contract it is mutually understood that the time extensions for changes in the work will depend upon the extent, if any, by which the changes cause delay in the completion of the various element of construction. The change order granting the time extension may provide that the contract completion date will be extended only for those specific elements so delayed and that the remaining contract completion dates for all other portions of the work will not be altered and may further provide for an equitable readjustment of liquidated damages pursuant to the new completion schedule.

## 12.2 CLAIMS FOR ADDITIONAL COSTS

12.2.1 If the Contractor wishes to make a claim for an increase in the Contract Sum, he shall give the Architect written notice thereof within twenty (20) days after the occurrence of the event giving rise to such claim. This notice shall be given by the Contractor before proceeding to execute the Work, except in an emergency endangering life or property in which case the Contractor shall proceed in accordance Subparagraph 10.3.1. No such claim shall be valid unless so made. If the Owner and the Contractor cannot agree on the amount of the adjustment in the Contract Sum it shall be determined by Arbitration, Paragraph 7.9. Any change in the Contract Sum resulting from such claim shall be authorized by Change Order.



**ARTICLE 13.00  
UNCOVERING AND CORRECTION OF WORK**

13.1 UNCOVERING OF WORK

13.1.1 If any Work should be covered contrary to the request of the Architect, it must, if required by the Architect, be uncovered for his observation and replaced, at the Contractor's expense.

13.1.2 If any other Work has been covered which the Architect has not specifically requested to observe prior to being covered, the Architect may request to see such Work and it shall be uncovered by the Contractor. If such Work be found in accordance with the Contract Documents, the cost of uncovering and replacement shall, by appropriate Change Order, be charged to the Owner. If such Work be found not in accordance with the Contract Documents, the Contractor shall pay such costs unless it be found that this condition was caused by a separate contractor employed as provided in Article 6, and in that event the Owner shall be responsible for the payments of such costs.

13.2 CORRECTION OF WORK

13.2.1 The Contractor shall promptly correct all Work rejected by the Architect as defective or as failing to conform to the Contract Documents whether observed before or after Substantial Completion and whether or not fabricated, installed or completed. The Contractor shall bear all costs of correcting such rejected Work, including the cost of the Architect's additional services thereby made necessary.

13.2.2 If, within one (1) year after the date of the approval of the Certificate of Final Inspection by the Florida Department of Education or by the terms of any applicable special guarantee required by the Contract Documents, any of the Work is found to be defective or not in accordance with the Contract Documents, the Contractor shall correct it promptly after receipt of a written notice from the Owner to do so unless the Owner has previously given the Contractor a written acceptance of such condition. The Owner shall give such notice promptly after discovery of the condition.

13.2.3 All such defective or non-conforming Work under Subparagraph 13.2.1 and 13.2.2 shall be removed from the site if necessary, and the Work shall be corrected to comply with the Contract Documents without cost to the Owner.

13.2.4 The Contractor shall bear the cost of making good all work of separate contractors destroyed or damaged by such removal or correction.

13.2.5 If the Contractor does not remove such defective or non-conforming Work within a reasonable time fixed by written notice from the Architect, the Owner may remove it and may store the materials or equipment at the expense of the Contractor. If the Contractor does not pay the cost of such removal and storage within ten (10) days thereafter, the Owner may upon ten (10) additional days' written notice sell such Work at auction or at private sale and shall account for the net proceeds thereof, after deducting all the costs that should have been borne by the Contractor including compensation for additional architectural services. If such proceeds of sale do not cover all costs which the Contractor should have borne, the difference shall be charged to the Contractor and an appropriate Change Order shall be issued. If the payments then or thereafter due the Contractor are not sufficient to cover such amount, the Contractor shall pay the difference to the Owner.

13.2.6 If the Contractor fails to correct such defective or non-conforming Work, the Owner may correct it in accordance with Paragraph 3.4.

13.3 ACCEPTANCE OF DEFECTIVE OR NON-CONFORMING WORK

13.3.1 If the Owner prefers to accept defective or non-conforming Work, he may do so instead of requiring its removal and correction, in which case a Change Order will be issued to reflect an

appropriate reduction in the Contract Sum, or, if the amount is determined after final payment, it shall be paid by the Contractor.

## **ARTICLE 14.00 TERMINATION OF CONTRACT**

### **14.1 TERMINATION BY THE CONTRACTOR**

14.1.1 If the Work is stopped for a period of thirty (30) days under any order of any court or other public authority having jurisdiction, or as a result of an act of government, such as a declaration of a national emergency making materials unavailable, through no act or fault of the Contractor or a Subcontractor or their agents or employees or any other persons performing any of the Work under a contract with the Contractor, or if the Work should be stopped for a period of thirty (30) days by the Contractor for the Architect's failure to issue a Certificate for Payment as provided in Paragraph 9.5 or for the Owner's failure to make payment thereon as provided in Paragraph 9.5, then the Contractor may, upon seven (7) days' written notice to the Owner and the Architect, terminate the Contract and recover from the Owner payment for all Work executed and for any proven loss sustained upon any materials, equipment, construction equipment, tools, and machinery, including reasonable profit and damages.

### **14.2 TERMINATION FOR DEFAULT-DAMAGES FOR DELAY-TIME EXTENSIONS**

14.2.1 If the Contractor persistently or repeatedly refuses or fails, except in cases for which extension of time is provided, to prosecute the Work, or any separable part thereof, with such diligence as will insure its completion within the time specified in this Contract, or any extension thereof, or fails to complete said work within such time, the Owner may, upon seven (7) days written notice to the Contractor, and his surety, if any, terminate his right to proceed with the Work or such part of the Work as to which there has been delay. In such event the Owner may take over the Work and prosecute the same to completion, by contract or otherwise, and may take possession of and utilize in completing the work such materials, appliances, and plant as may be on the site of the Work and necessary therefore. Whether or not the Contractor's right to proceed with the work is terminated, he and his sureties shall be liable for any damage to the Owner resulting from his refusal or failure to complete the Work within the specified time.

14.2.2 If fixed and agreed liquidated damages are provided in the Contract and if the Owner so terminates the Contractor's right to proceed, the resulting damage will consist of such liquidated damages until such reasonable time as may be required for final completion of the work together with any increased costs occasioned the Owner in completing the work.

14.2.3 If fixed and agreed liquidated damages are provided in the Contract and if the Owner does not so terminate the Contractor's right to proceed, the resulting damage will consist of such liquidated damages until the work is completed or accepted.

14.2.4 The Contractor's right to proceed shall not be so terminated nor the Contractor charged with resulting damage if:

14.2.4.1 The delay in the completion of the work arises from unforeseeable causes beyond the control and without the fault or negligence of the Contractor, including but not restricted to, acts of God, acts of a public enemy, acts of the Owner in its contractual capacity, acts of other Contractor in the performance of a contract with the Owner, fires, floods, epidemics, quarantine restrictions, strikes, freight embargoes, unusually severe weather conditions not reasonably anticipated based on Weather Bureau five (5) year averages for the contract period, or delays of subcontractors or suppliers (at any tier) arising from unforeseeable causes beyond the control and without the fault or negligence of both the Contractor and such subcontractors or suppliers; and

14.2.4.2 The Contractor, within ten (10) days from the beginning of such delay (unless the Owner grants a further delay of time in writing before the date of final payment under the Contract), notifies the Architect in writing of the causes of delay. The Architect shall ascertain the facts and extent of the delay and, with agreement of the Owner, extend the time for completing the Work when, in his judgment, the findings of facts justify such an extension. A Change Order will be executed pursuant to Article 12 to reflect the change in Contract Time.

14.2.5 If, after notice of termination of the Contractor's right to proceed under the provisions of this Paragraph, it is determined for any reason that the Contractor was not in default, or that the delay was excusable, the Contract shall be equitably adjusted to compensate for such termination and the Contract modified accordingly. Failure to agree to any such adjustment shall be resolved in arbitration pursuant to Paragraph 7.9 ARBITRATION.

14.2.6 The rights and remedies of the Owner provided in this Paragraph are in addition to any other rights and remedies provided by law or under this Contract.

#### 14.3 TERMINATION FOR OTHER REASONS

14.3.1 If the Contractor is adjudged bankrupt, or if he makes a general assignment for the benefit of his creditors, or if a receiver is appointed on account of his insolvency, or if he persistently or repeatedly refuses or fails to supply enough properly skilled workmen or proper materials, or if he fails to make prompt payment to Subcontractors for materials or labor, or persistently disregards laws, ordinances, rules, regulations or orders of any public authority having jurisdiction, or otherwise is guilty of a substantial violation of a provision of the Contract Documents, then the Owner, upon certification by the Architect that sufficient cause exists to justify such action, may, without prejudice to any right or remedy and after giving the Contractor and his surety, if any, seven (7) days' written notice, terminate the employment of the Contractor and take possession of the site and of all materials, equipment, tools, construction equipment and machinery thereon owned by the Contractor and may finish the Work by whatever method he may deem expedient.

#### 14.4 FURTHER PAYMENTS

14.4.1 In the event of termination under Paragraphs 14.2 and 14.3 the Contractor shall not be entitled to receive any further payment until the Work is finished. If the unpaid balance of the Contract Sum exceeds the costs of finishing the Work, including compensation for the Architect's additional services, such excess shall be paid to the Contractor. If such costs exceed such unpaid balance, the Contractor shall pay the difference to the Owner. The costs incurred by the Owner as herein provided shall be certified by the Architect.

#### 14.5 ABANDONMENT OF THE PROJECT

14.5.1 Upon seven (7) days' written notice to the Contractor and the Architect, the Owner may, without cause and without prejudice to any other right or remedy, elect to abandon the Project and terminate the Agreement. In such case, the Contractor shall be paid for all Work executed and any expense sustained, plus a reasonable profit.

### **ARTICLE 15.00 EQUAL OPPORTUNITY**

#### 15.1 EQUAL OPPORTUNITY

15.1.1 All jobs let based on bids received or contracts negotiated will be guaranteed by the individual Contractor or Subcontractor or Sub-subcontractor as to compliance with any and all applicable laws, rules and regulations relating to equal employment opportunity, and any Federal, State and Local Laws, rules and regulations pertaining hereto. The Contractor shall execute the certificate as provided in Attachment Number 5 as evidence of such compliance and file it with the Owner simultaneously with the Contractor's execution of the agreement.

15.1.2 Pursuant to Florida Statute 112.313(7) No employee (including part time employees, or adjunct employees) shall sell any product or service to the COLLEGE Board except as may be specified in the employee's position responsibilities at the College".

**If your company has any employees that own >5% of your company and is also a College employee, you must submit with your bid document a detailed description of their name and relationship within the company.**

## **ARTICLE 16.00 PROTEST**

### 16.1 PROTEST OF BID/PROPOSAL

16.1.1 Any notice of protest involving the specifications, the terms and conditions or any other aspect of the Invitation To Bid must be filed within 72-hours after the receipt of the solicitation, however protests will not be considered if the notice of protest letter is not delivered prior to 72-hours after the solicitation was issued (Saturdays, Sundays and state holidays shall be excluded in the computation of the 72-hour time periods). The formal written protest shall be filed within 10 days after the date of the notice of protest is filed. Failure to file a notice of protest within the time prescribed shall constitute a waiver of proceedings under Chapter 120, Florida Statutes.

"Failure to file a protest within the time prescribed in section 120.57(3), Florida Statutes, or failure to post the bond or other security required by law within the time allowed for the filing a bond shall constitute a waiver of proceedings under chapter 120, Florida Statutes".

### 16.2 POSTING OF BID TABULATIONS

16.2.1 Bid tabulations with recommended awards will be posted for review by interested parties on Pensacola State College's Purchasing website and will remain posted for a period of 72-hours (Saturdays, Sundays and state holidays shall be excluded in the computation of the 72-hour time periods). Their content will be made public for the information of bidders and others interested, and those who may be present either in person or by representative on the College's Purchasing Department website for a 72-hour period.

Any notice of protest of award or recommendation of award shall be filed in writing within 72-hours with a protest bond amounting to (1) Twenty-five Thousand dollars (\$25,000) or Two percent (2%) of the lowest accepted bid, whichever is greater, for projects valued over \$500,000; and (2) Five percent (5%) of the lowest accepted bid for all other projects (as defined in section 255.0516 Florida Statutes) after the posting of the bid tabulation and a formal written protest shall be filed within 10 days after date the notice of protest was filed. Failure to file a protest and protest bond within the time prescribed shall constitute a waiver of proceedings under Chapter 120, Florida Statutes.

## **REQUIRED DOCUMENTATION TO BE SUBMITTED**

Bidders must provide the following documentation as specified below. Failure to provide any of the required documents with the bid may result in the vendor being disqualified.

Proposal Form

List of Designated Subcontractors Form

Bond Certificates

Insurance Documentation

State of Florida Certificate of Incorporation

City of Pensacola/Escambia County Business Tax Receipt

Public Entity Crimes Certificate

Equal Opportunity Certificate of Compliance

Minority Business Enterprise/Woman Business Enterprise Certificate (if applicable)

Certification of Drug-Free Workplace Program

References Form

Licensure Documentation as Florida Commercial Pool Contractor

**Proposal Form**

Project: **ITB 2-2013/2014, New Pool Piping/Equipment and Liner**

Bidder in submitting this proposal attests full agreement to the following:

1. To be Responsive: Bidder shall accomplish the work in strict compliance in accordance with the specifications.
2. Provide and maintain a Florida Commercial Pool Contractor or General Contractor's License authorizing firm to perform the scope of work herein. Attach a copy of your firm's current State of Florida Commercial Pool Contractor or General Contractor's License along with your firm's Escambia County Business Tax Receipt to your proposal submission.
3. To hold this quoted bid prices firm and fixed for sixty (60) days after the date of public opening of bids;
4. To accept the provisions of "Instructions to Bidders" regarding the disposition and forfeiture of the Proposal Guarantee;
5. To enter into and execute Contract with the Owner, if awarded on the basis of this Proposal, and if the cumulative award exceeds \$200,000 to furnish the Owner a Contract 100% Performance and Payment Bond from a surety authorized to do business in Florida that complies with Section 255.05 F.S. and Insurance Certificate (as specified) in the Contract Documents;
6. To complete the work in accordance with the Contract Documents; without exception or exclusion.
7. To complete the work in accordance with the Contract Time specified in the section titled "Supplementary Conditions", "Contract Time."

**LUMP SUM BASE BID**

Proposed lump sum price for the work complete and acceptable except for work set forth in the Alternate Bid Items, if any:

\_\_\_\_\_ Dollars (\$ \_\_\_\_\_)

Bid Submitted By:

<b>Federal Tax ID Number</b>	
<b>Firm or Entity Name</b>	
<b>Address</b>	
<b>City, State, &amp; Zip Code</b>	
<b>Telephone Number</b>	
<b>Fax Number</b>	
<b>Email Address</b>	
<b>Typed or Printed Name of Representative</b>	
<b>Signature of Representative</b>	

**Minority Business Enterprise/Woman Business Enterprise Certification**

Project: **ITB 2-2013/2014, New Pool Piping/Equipment and Liner**

I hereby declare and affirm that I am the \_\_\_\_\_(Title) representative of the firm of \_\_\_\_\_ (Company) minority business enterprises (MBE/WBE) \_\_\_\_\_ (Minority Type), and I will provide information requested by the College to document this fact. The foregoing statements are true and correct and include all material necessary to identify and explain the operations of the above referenced firm as well as the ownership thereof. Further, the undersigned does agree to provide the College current, complete and accurate information regarding actual work performed on the project, the payment therefor and any proposed changes in any of the arrangements hereinabove stated and to permit and audit an examination in any of the records and files of the above named company by an authorized representative of the College. It is recognized and acknowledged the statements herein are being given under oath and material misrepresentation will be grounds for terminating any contract which may be awarded in reliance hereon. Termination is understood to provide forfeiture of payment for all work not performed at the time of notification.

I do solemnly declare or affirm under the penalties of perjury the contents of the foregoing documents are true and correct, and I am authorized on behalf of the firm above to make this affidavit.

\_\_\_\_\_  
Signature of Company's Authorized Representative

State of \_\_\_\_\_ County of \_\_\_\_\_ City of \_\_\_\_\_ on this \_\_\_\_\_ day of \_\_\_\_\_, 20\_\_\_\_, before me, in the foregoing affidavit and acknowledged that (s)he executed the same in the capacity therein stated and for the purpose therein contained. In witness thereof, I hereunto set my hand and official seal.

\_\_\_\_\_  
Notary Public

\_\_\_\_\_  
My commission Expires

Minority Type: M1 Black American Man; M2 Hispanic American; M3 Asian American; M4 Native American; M5 Native Hawaiian; M6 Small Business; M7 Disabled; M8 American Woman; M9 Black American Woman; and NM Not Minority. Must have greater than 51% ownership.

Minority/Woman Business Enterprises that file false misrepresentation of their MBE/WBE status shall be found guilty of a felony of the second degree and be debarred from bidding no less than 36 months pursuant to 287.094, Florida Statute.

**List of Designated Subcontractors Form**

Project: **ITB 2-2013/2014, New Pool Piping/Equipment and Liner**

TO BE RESPONSIVE THIS FORM (WITH DEFINED TRADE SUBCONTRACTOR'S NAME AND SUBCONTRACT AMOUNT COMPLETED) SHALL BE SIGNED AND PLACED IN AN ENVELOPE, SEALED AND SUBMITTED WITH CONTRACTOR'S BID. (F.S. 255.0515) The College will require the apparent low bidder meeting specification to submit in writing (on this form) within 24 hours after notice all additionally required information defined below (i.e. address, minority type and subcontractor license numbers) if not provided at bid opening.

NOTE: The College reserves the right to consider a bidder/proposer non responsive if they have not submitted with their bid/proposal a comprehensive, completed, signed minority outreach statement, as deemed in the Colleges best interest.

The following names are the subcontractors for designated trades who will perform the phases of the work indicated (use additional forms as needed to specify any additional subcontractors):

<b>Subcontractors to be used</b>					
Required to be submitted with Proposal			Required from the apparent low bidder within 24 hours of notice		
<b>Trade</b>	<b>Name of Company (if self-performed, so indicate)</b>	<b>Subcontract Value</b>	<b>Address</b>	<b>Minority Type</b>	<b>FL Trade License/ Occupational Number</b>

The undersigned declares that he/she has fully investigated each subcontractor listed and has received and has in his/her files evidence that each entity is currently licensed in the State of Florida and maintains a fully equipped, licensed organization capable, technically and financially, capable of performing the pertinent work, and that he has made similar installations in a satisfactory manner, and that no employees of the subcontractor are currently employees of by the College.

Firm Name: \_\_\_\_\_

Firm Representative: \_\_\_\_\_

Signature: \_\_\_\_\_

Date: \_\_\_\_\_



**CERTIFICATION OF DRUG-FREE WORKPLACE PROGRAM**

Project: ITB 2-2013/2014, New Pool Piping/Equipment and Liner

Whenever two or more bids which are equal with respect to price, quality, and service are received by the State or by any political subdivision for the procurement of commodities or contractual services, a bid received from a business that certifies that it has implemented a drug-free workplace program shall be given preference in the award process. Established procedures for processing tie bids will be followed if none of the tied vendors have a drug-free workplace program, or if all of the tied vendors have drug-free workplace programs. In order to have a drug-free workplace program a business shall:

- (1) Publish a statement notifying employees that the unlawful manufacture, distribution, dispensing, possession, or use of a controlled substance is prohibited in the workplace and specifying the actions that will be taken against employees for violations of such prohibition.
- (2) Inform employees about the dangers of drug abuse in the workplace, the business's policy of maintaining a drug-free workplace, any available drug counseling, rehabilitation, and employee assistance programs, and the penalties that may be imposed upon employees for drug abuse violations.
- (3) Give each employee engaged in providing the commodities or contractual services that are under bid a copy of the statement specified in subsection (1).
- (4) In the statement specified in subsection (1), notify the employees that, as a condition of working on the commodities or contractual services that are under bid, the employee will abide by the terms of the statement and will notify the employer of any conviction of, or plea of guilty or nolo contendere to, any violation of chapter 893 or of any controlled substance law of the United States or any state, for a violation occurring in the workplace no later than five (5) days after such conviction.
- (5) Impose a sanction on, or require the satisfactory participation in a drug abuse assistance or rehabilitation program if such is available in the employee's community, by any employee who is so convicted.
- (6) Make a good faith effort to continue to maintain a drug-free workplace through implementation of this section.

AS THE PERSON AUTHORIZED TO SIGN THE STATEMENT, I CERTIFY THAT THIS FIRM COMPLIES FULLY WITH THE ABOVE REQUIREMENTS.

Firm Name: \_\_\_\_\_

Firm Representative: \_\_\_\_\_

Signature: \_\_\_\_\_

Date: \_\_\_\_\_

**PUBLIC ENTITY CRIMES CERTIFICATION**

Project: **ITB 2-2013/2014, New Pool Piping/Equipment and Liner**

A person or affiliate who has been placed on the convicted vendor list following a conviction for a public entity crime may not submit a bid on a contract to provide any goods or services to a public entity, may not submit a bid on a contract with a public entity for the construction or repair of a public building or public work, may not submit bids on leases of real property to a public entity, may not be awarded or perform work as a contractor, supplier, subcontractor, or consultant under a contract with any public entity, and may not transact business with any public entity in excess of the threshold amount provided in section 287.017, for category two for a period of 36 months from the date of being placed on the convicted vendor list.

DISCRIMINATION: In accordance with HB 2127, Section 6(3)(a), all Invitations To Bid, as defined by 287.012(11)FS, requests for proposals, as defined by 287.012(15), and any written contract document of the State shall contain a statement informing entities of the discrimination provisions of paragraph (2)(a).

An entity of affiliate who has been placed on the discriminatory vendor list may not submit a bid on a contract to provide goods or services to a public entity, may not submit a bid on a contract with a public entity for the construction or repair of a public building or public work, may not submit bids on leases of real property to a public entity, may not award or perform work as a contractor, supplier, subcontractor, or consultant under contract with any public entity, and may not transact business with any public entity.

AS THE PERSON AUTHORIZED TO SIGN THE STATEMENT, I CERTIFY THAT THIS FIRM DOES NOT FALL WITHIN THE PARAMETERS OF REPORTING AS AN ENTITY WHO HAS BEEN PLACED ON THE CONVICTED VENDOR LIST.

Firm Name: \_\_\_\_\_

Firm Representative: \_\_\_\_\_

Signature: \_\_\_\_\_

Date: \_\_\_\_\_

## EQUAL OPPORTUNITY CERTIFICATE OF COMPLIANCE

Project: **ITB 2-2013/2014, New Pool Piping/Equipment and Liner**

This is to certify that the undersigned contractor on subject project does now and will during the entire length of this project comply with all applicable laws, rules and regulations relating to equal employment opportunity, and any Federal, State, or Local laws, rules, or regulations pertaining thereto; and further certifies compliance specifically with Executive Order 11246 originally issued by the President of the United States on September 24, 1965, as amended from time to time thereafter, including:

1. The Contractor does not discriminate in any manner in its employment policies as to race, color, religion, sex or national origin; and,
2. The Contractor does maintain an affirmative action plan to recruit, employ, and promote qualified members of groups that may have been formerly excluded because of race, color, religion, sex or national origin.

Firm Name: \_\_\_\_\_

Firm Representative: \_\_\_\_\_

Signature: \_\_\_\_\_

Date: \_\_\_\_\_

**REFERENCES**

Project: **ITB 2-2013/2014, New Pool Piping/Equipment and Liner**

1. \_\_\_\_\_  
COMPANY NAME CONTACT PERSON

\_\_\_\_\_  
EMAIL ADDRESS PHONE NUMBER

\_\_\_\_\_  
DATE OF LAST SERVICE PROVIDED

\_\_\_\_\_  
PROJECT SIZE

2. \_\_\_\_\_  
COMPANY NAME CONTACT PERSON

\_\_\_\_\_  
EMAIL ADDRESS PHONE NUMBER

\_\_\_\_\_  
DATE OF LAST SERVICE PROVIDED

\_\_\_\_\_  
PROJECT SIZE

3. \_\_\_\_\_  
COMPANY NAME CONTACT PERSON

\_\_\_\_\_  
EMAIL ADDRESS PHONE NUMBER

\_\_\_\_\_  
DATE OF LAST SERVICE PROVIDED

\_\_\_\_\_  
PROJECT SIZE

Number of Years of Experience in the installation of pool systems: \_\_\_\_\_ Years

Firm Name: \_\_\_\_\_

Firm Representative: \_\_\_\_\_

Signature: \_\_\_\_\_

Date: \_\_\_\_\_

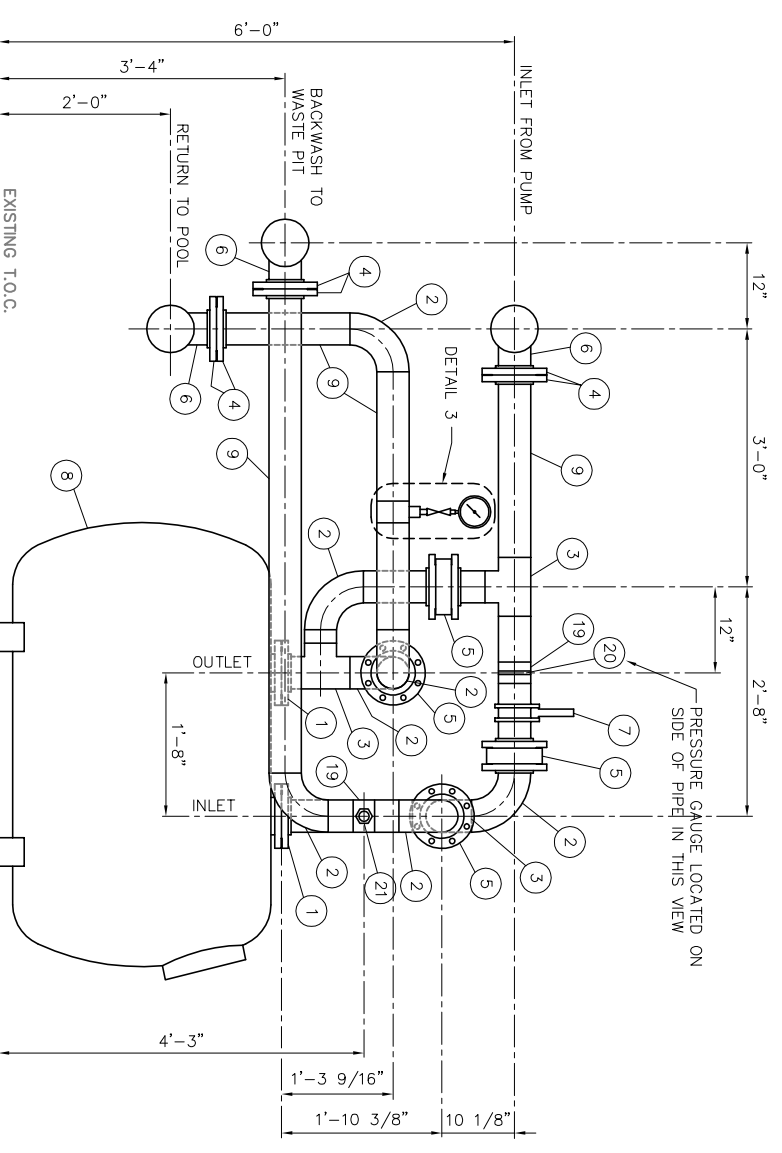

**SECTION A-A**  
SCALE: 1" = 1'-0"

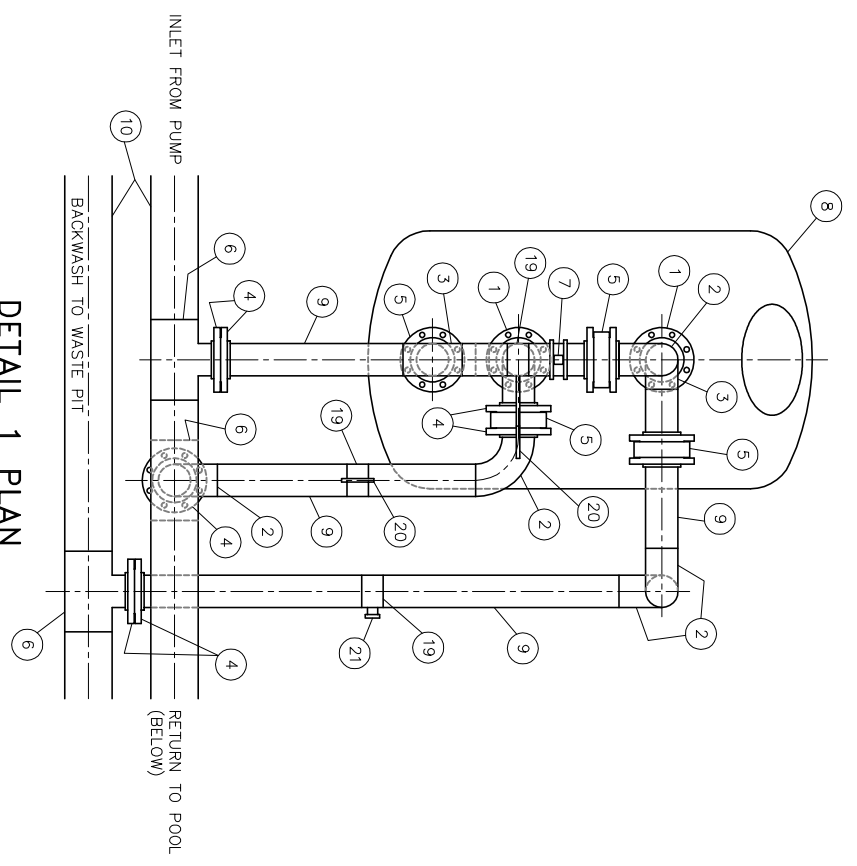

**DETAIL 1 PLAN**  
SCALE: 1" = 1'-0"

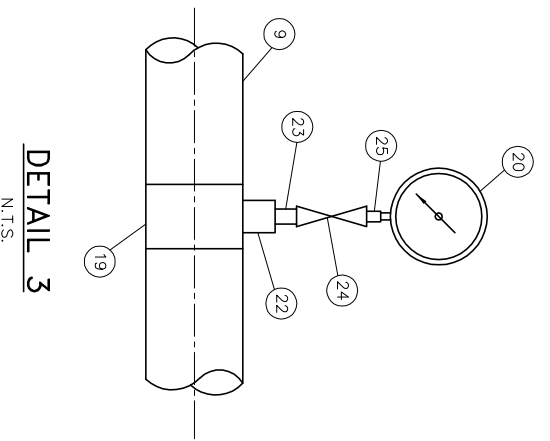

**DETAIL 3**  
N.T.S.

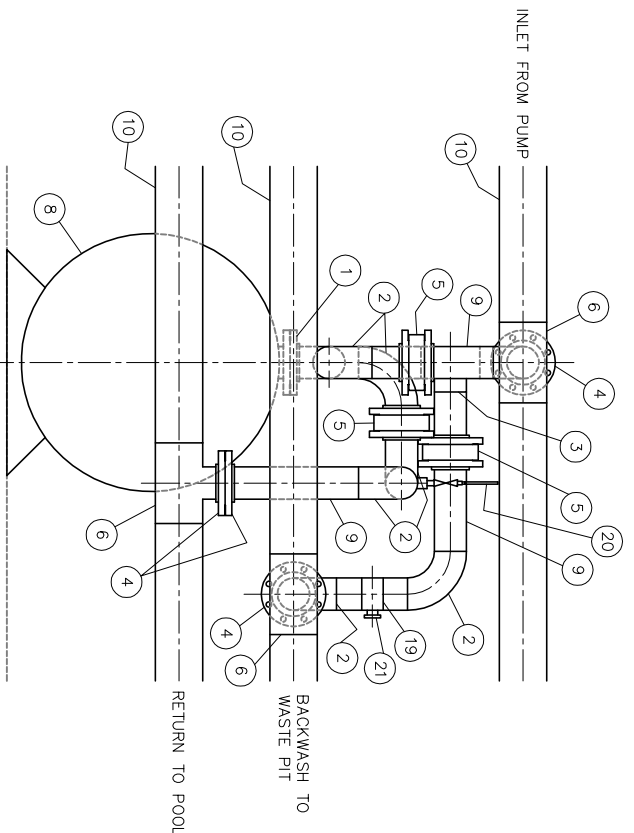

**DETAIL 2**  
SCALE: 1" = 1'-0"

**BILL OF MATERIAL**

MK	QTY	SIZE	DESCRIPTION
1	6	4"	MECHANIC FIRELOCK FLANGE
2	25	4"	EL. 90° L.R., SCH. 40 PVC
3	10	4"x4"x4"	TEE, SCH. 40 PVC
4	48	4"	FLANGE, 150# RFSO, PVC (TOTAL INCLUDES 2 FLANGES FOR EACH BUTTERFLY VALVE)
* 5	14	4"	BUTTERFLY VALVE, 150#, PVC
6	6	6"x6"x4"	TEE, SCH. 40 PVC
7	3	4"	FLOW METER, BLUE-WHITE #30400P
8	3	3/4"x6 1/2"	SAND FILTER, PENTAIR MODEL THS3461
9	84	4"	PIPE, SCH. 40 PVC
10	95	L.F.	PIPE, SCH. 40 PVC
11	2	-	PUMP, PENTAIR ECK-1000 w/STRAINER
12	6	6"	EL. 90° L.R., SCH. 40 PVC
13	1	6"x6"x6"	TEE, SCH. 40 PVC
14	2	6"	BUTTERFLY VALVE, 150#, PVC
15	6	6"	FLANGE, 150# RFSO, PVC
16	1	8"x6"	CONCENTRIC REDUCER, SCH. 40 PVC
17	1	8"	FLANGE, 150# RFSO, PVC
18	3	6"x4"	CONCENTRIC REDUCER, SCH. 40 PVC
19	9	4"x1 1/2"	SADDLE TAP, THREADED, SCH. 40 PVC
20	6	4 1/2"	PRESSURE GAUGE, 0-60 PSI, 1/4" NPT.
21	3	-	SIGHT PLUG GAGE, NPT 1 1/2-11 1/2 IN., 0-750 PSI, OPEN VIEW GLASS
22	6	1 1/2"x1/2"	BUSHING, SCH. 40 PVC
23	6	1/2"	NIPPLE, SCH. 40 PVC
24	6	1/2"	BALL VALVE, 150#, PVC
25	6	1/2"x1/4"	BUSHING, SCH. 40 PVC

\* 2 FLANGES WITH EACH BUTTERFLY VALVE (INCLUDED IN FLANGE TOTALS).

**NOTES:**

- ON DETAILS 1 AND 2, ALL MATERIAL CALL-OUTS TYPICAL EACH SAND FILTER, UNLESS NOTED OTHERWISE ON DWG. M1.

A	FOR APPROVAL	05/13/13
No.	Revision/Issue	Date

Firm Name and Address  
**CORNERSTONE FACILITIES ENGINEERING, INC.**  
 P.O. Box 12292  
 Pensacola, Florida 32591  
 (850) 438-3449  
 CERTIFICATE OF AUTHORIZATION #Z7540

Project Name and Address  
**PENSACOLA STATE COLLEGE**  
 PENSACOLA, FLORIDA  
 NEW POOL PIPING/EQUIPMENT SECTIONS & DETAILS

Date: 05/08/13  
 Scale: 1" = 1'-0"  
 Drawn By: MLM  
 Sheet: M2

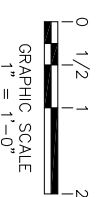

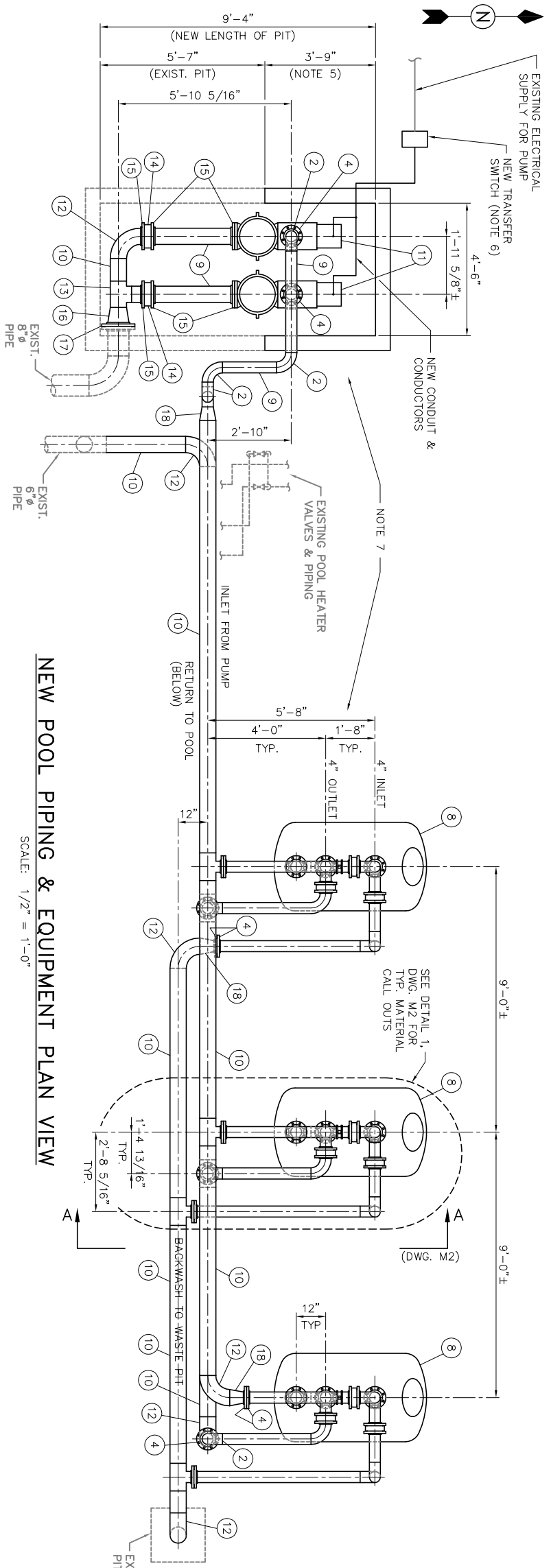

**NEW POOL PIPING & EQUIPMENT PLAN VIEW**  
SCALE: 1/2" = 1'-0"

- NOTES:**
1. ALL PIPE AND FITTINGS TO BE SCH. 40 PVC U.N.O.
  2. SUPPORT PIPE EVERY 4 FEET. IF FLOOR SUPPORTED, PIPING SUPPORTS TO BE CONSTRUCTED FROM ALUMINUM, STAINLESS STEEL, FRP OR OTHER NON-CORROSIVE MATERIAL. IF PIPE HANGERS ARE USED, RODS TO BE STAINLESS STEEL WITH EITHER STAINLESS STEEL OR FRP HANGERS.
  3. ALL CONNECTIONS & FITTINGS TO BE PVC GLUED U.N.O.
  4. FOR BILL OF MATERIAL, SEE DWG. M2.
  5. SAWCUT CONCRETE TO LENGTHEN PIT TO 9'-4" OVERALL. WORK TO INCLUDE REQUIRED SAWCUTTING OF EXISTING CONCRETE, EXCAVATION, FORMING AND PLACEMENT OF NEW 3000 PSI CONCRETE. VERIFY PUMP BASE CONCRETE ELEVATION TO COORDINATE WITH EXISTING 8" PIPE ELEVATION. ADJUST AS REQUIRED.
  6. FURNISH AND INSTALL A NEW, 3-PHASE PUMP TRANSFER SWITCH, SWITCH TO HAVE THREE POSITIONS LABELED, "PUMP 1", "OFF", "PUMP 2". PROVIDE AND INSTALL CONDUIT AND CONDUCTORS TO NEW MOTORS.
  7. WORK TO INCLUDE DEMOLITION AND DISPOSAL OF EXISTING FILTERS, PIPING AND PUMP TO MAKE SPACE FOR NEW WORK SHOWN ON PLANS.

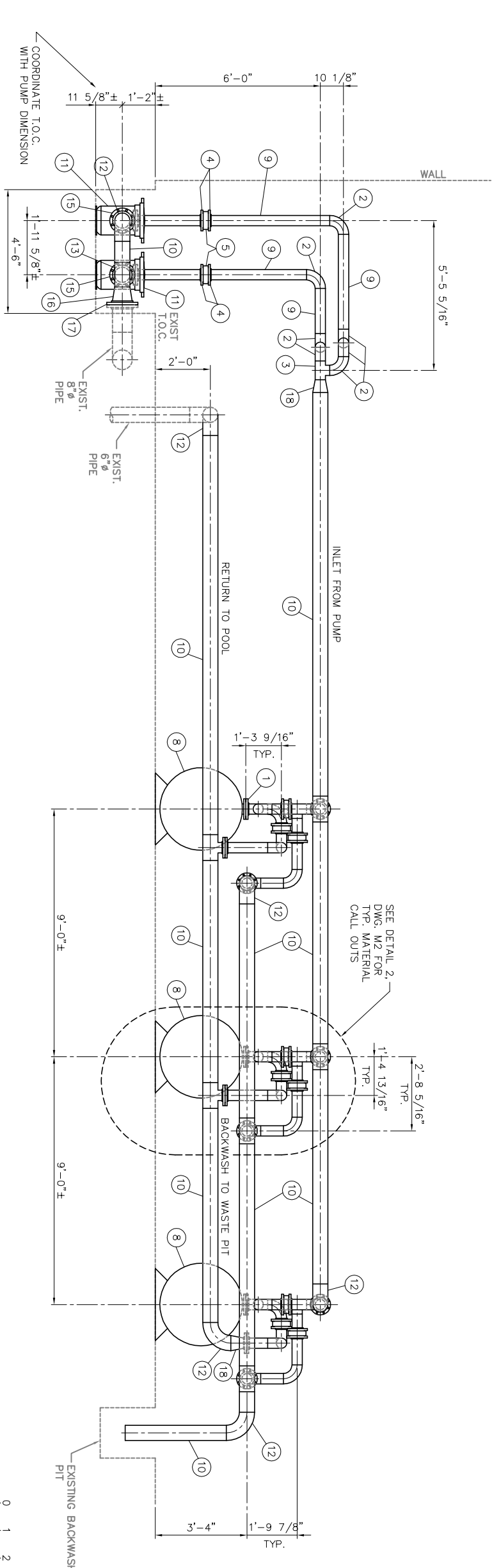

**NEW POOL PIPING & EQUIPMENT SOUTH ELEVATION**  
SCALE: 1/2" = 1'-0"

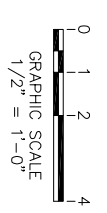

Date 05/08/13	Sheet M1
Scale 1/2" = 1'-0"	Drawn by MLM

Project Name and Address <b>PENSACOLA STATE COLLEGE</b> PENSACOLA, FLORIDA
Firm Name and Address <b>CORNERSTONE FACILITIES ENGINEERING, INC.</b> P.O. Box 12992 Pensacola, Florida 32591 (850) 438-3449 CERTIFICATE OF AUTHORIZATION #27540
No. A Revision/Issue Date 05/13/13
FOR APPROVAL

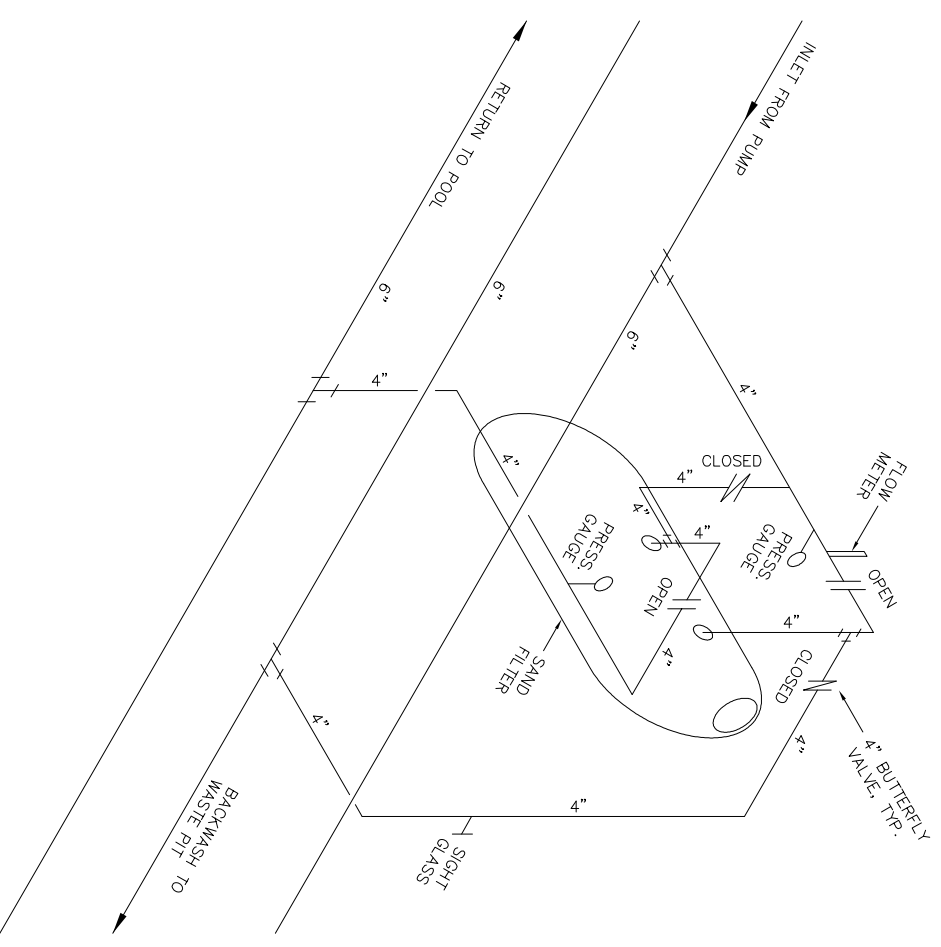

**NORMAL FILTER OPERATION**  
NTS

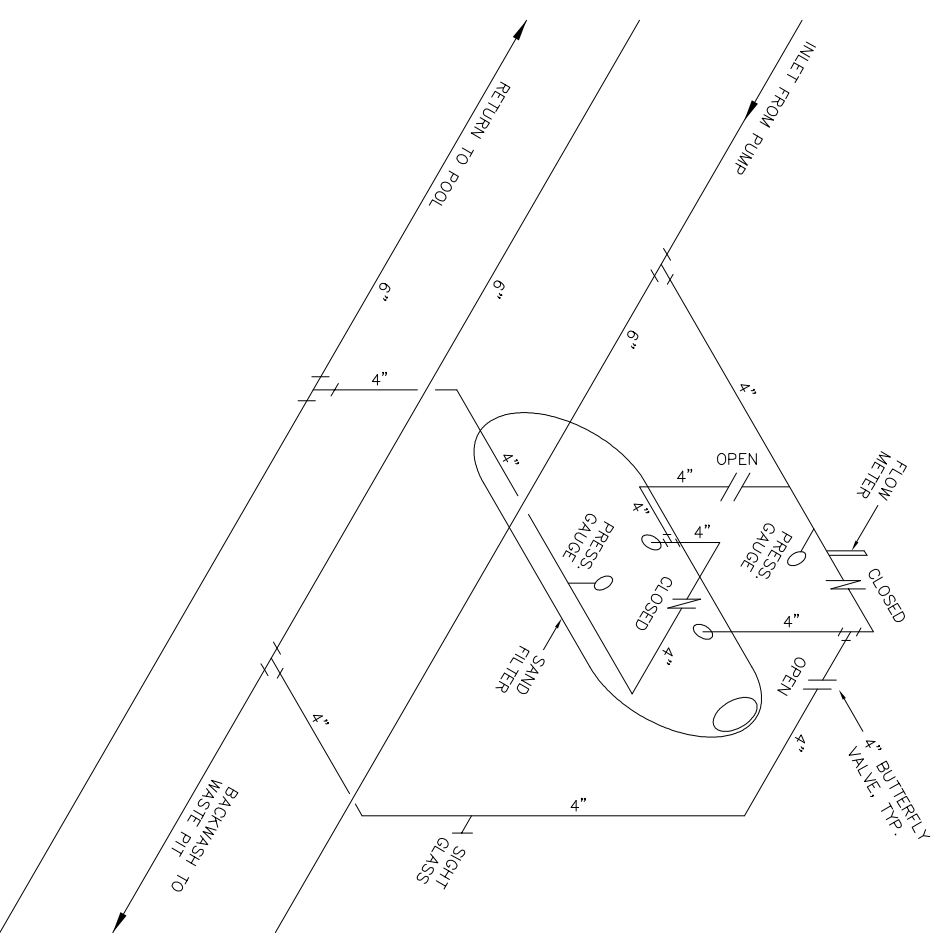

**BACKWASH OPERATION**  
NTS

No.	Revision/Issue	Date
A	FOR APPROVAL	05/13/13

Firm Name and Address  
**CORNERSTONE FACILITIES ENGINEERING, INC.**  
 P.O. Box 12292  
 Pensacola, Florida 32591  
 (850) 438-3449  
 CERTIFICATE OF AUTHORIZATION #Z7540

Project Name and Address  
**PENSACOLA STATE COLLEGE**  
 PENSACOLA, FLORIDA  
 NEW POOL PIPING/EQUIPMENT ISO'S

Date	05/08/13	Sheet
Scale	NTS	M3
Drawn By	MLM	